

MOTOREN DESMEDT NV

Moerelei 145, B-2610 Antwerpen, Belgium

+32(0)3830.09.90 +32(0)3828.78.90

www.motorendesmedt.be info@motorendesmedt.be

BARTEC **VARNOST**



General range of flameproof electrical motors

Individual solutions are our standard

BARTEC VARNOST

The plant itself came into being in 1957 as one of the small working units of the Zagorje coal mine. Five years later, in 1962, it became a separate company called "TEVE VARNOST". Numerous organizational restructurations took place during the following years and in 1997 the company was taken over by BARTEC to become "BARTEC VARNOST".

BARTEC Motors and electrical equipment

BARTEC develops and manufactures electric motors and electrical equipment for safe and reliable solutions in power, lighting, control and monitoring applications.

Our production program includes:

- Electric motors
- Special motors and special solutions
- Switches and controllers
- Lighting systems

All products can be supplied for potentially explosive atmospheres, wet environments or tailored to our customers' requirements.



BARTEC VARNOST, Zagorje

Contents

1	<i>Ignition temperature - temperature class</i>	2
2	<i>Maintenance of explosion protection</i>	3
3	<i>Introduction</i>	4
4	<i>Construction</i>	5
	Construction	6
	Dimensions	6
	Type codes	6
	Bearings	7-8
	Shaft ends	9
	Allowable radial force	10
	Maximum axial loads, noise level and vibrations	11
	Noise level and vibrations	12
	Terminal box and terminals for supply cable	13 - 14
	Mechanical protection and coating	15
	Arrangements	16
	Explosion protection and certificates	16
	Electric system	17
	Windings	18
	Test and tolerance band of the rated values	19
	Start-up characteristics	20
	Duty cycles	21 - 22
	Tables with ratings for single-speed motors	23 - 30
	Technical data and tables with ratings for pole changing motors	31 - 44
	Three phase motors supplied by frequency inverters	45 - 49
	Mounting dimensions	50
	Dimensions	51 -55
	Special execution	56 - 59
	Special applications/options	60



1

Ignition temperature - temperature class

The ignition temperature is influenced by various factors such as size, shape, type and composition of a surface. In IEC 79-4, IEC, CENELEC and other standards the authorities have agreed on a "procedure for the determination of ignition temperature" with a limit approaching the lowest possible value.

The gases and vapours are classified into temperature classes. In accordance with these temperature classes, electrical equipment is tested for its maximum surface temperature to ensure that the possibility of ignition due to the surface temperature is excluded in normal and abnormal operation. The standards specify to which extent these standard values may be exceeded and determine the necessary safety margins.

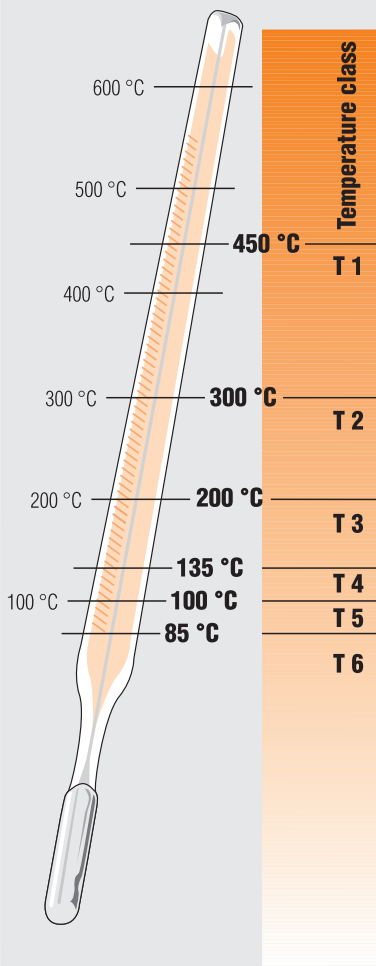

Temperature class	Ignition temperature range of mixture	Permissible surface temperature of electrical equipment	Permissible temperature rise
T1	> + 450 °C	+ 450 °C	+ 410 °C
T2	> + 300... ≤ + 450 °C	+ 300 °C	+ 260 °C
T3	> + 200... ≤ + 300 °C	+ 200 °C	+ 160 °C
T4	> + 135... ≤ + 200 °C	+ 135 °C	+ 95 °C
T5	> + 100... ≤ + 135 °C	+ 100 °C	+ 60 °C
T6	> + 85... ≤ + 100 °C	+ 85 °C	+ 45 °C

Examples of the categorisation of gases and vapours in temperature classes and explosion protection subgroups.

	T1	T2	T3	T4	T5	T6
IIA	Methane	Propane	Petrol	Acetaldehyde		
IIB		Ethylene	Diethylether			
IIC	Hydrogen	Acetylene				Carbon disulphide



2

Maintenance of explosion protection

Maintenance of explosion protection during operation.

Electric machines must be protected against overheating due to overloads. The type of protection depends on the type of operation as well as the electric machine and its use.

Explosion-proof electric motors are usually certified for S1 type of operation, i. e. continuous operation. Other duties are allowed only if the temperature of the motor is controlled by reliable devices.

Duty type	Protective control device
S1*	<p>A Motor safety switch according to IEC 34-1 (VDE 0165/9.83)</p> <p>B Motor safety switch and temperature sensors in windings as additional protection.</p> <p>C Only temperature sensors as major protection. Only allowed if motor is tested and certified and if all control devices (power supplies) used are certified.</p>
S2/S3*	<p>D Motor safety switch with switch-on time control and/or temperature sensors in windings as additional protection.</p> <p>E Temperature sensors in windings as major protection. Only allowed if motor is tested and certified and if all control devices (power supplies) used are certified.</p>
S4, S5, S6, S7, S8*	<p>F Temperature sensors in windings. Motor must be tested and only certified control devices may be used.</p>
Power supply by means of frequency converters	<p>G Thermal protection of motor by means of sensors in windings is allowed as the only (independent) protection if motor is tested at all power supply frequencies, maximum voltage and S1-S7 (S8) types of operation.</p> <p>H If motor protection and converter are tested and certified as a unit.</p>

* For explanation of duty cycles see pages 22-23



3

Introduction

Explosion-protected electric motors are used in industrial plants with a potentially explosive atmosphere containing inflammable fumes (vapours) or gases (i. e. chemical industry, oil refineries ...) as well as in mines where methane is present.

These are the three-phase, asynchronous electric motors with short-circuit rotor, explosion protected according to the CENELEC EN 60079-0, EN 60079-1, EN 60079-7 (IEC 60079-0, IEC 60079-1) standards.

The enclosures of electric motors are designed to be "flameproof" according to EN 60079-0 (IEC 60079-1). The terminal boxes could also be in "flameproof" design or also in "increased safety" design according to EN 60079-7 (IEC 60079-7).

The following regulations and standards have been considered in designing, manufacturing and testing of electric motors:

Standard	IEC international	EN-CENELEC Europe
Rotating electric machines - classification of insulation materials for electric machines	IEC 60034-1	EN 60034-1
Climatic protection (IP number) Protection against harmful contact and ingress of solids	IEC 60034-5	EN 60034-5
Cooling devices for electric machines	IEC 60034-6	EN 60034-6
Construction and mounting of electric rotating machines	IEC 60034-7	EN 60034-7
Marking of terminals and directions of rotating of electric machines	IEC 60034-8	EN 60034-8
Noise levels	IEC 60034-9	EN 60034-9
Starting performances of short-circuit motors at 50 Hz and voltages up to 660 V	IEC 60034-12	EN 60034-12
Limited vibration levels for electric machines	IEC 60034-14	EN 60034-14
Relation between terminal sizes and ratings of three-phase short-circuit surface-cooled electric motors	IEC 60072-1, DIN 42673/3	
Relation between terminal sizes and ratings for arrangements: IM B5, IM B10, IM B14	IEC 60072-2	

European directives

Description	Direct no.
Directive for explosive atmospheres (ATEX)	94/9/EC, 1999/92/EL
Electromagnetic Compatibility (EMC)	89/336/EEC
Low Voltage Directive (LVD)	73/23/EEC
Machinery Directive	98/37/EC
Packing and packaging waste	94/62/EC



4

Construction

Explosion protection standards taken into consideration during manufacturing and testing

Standard	IEC international	EN-CENELEC Europe
Electric devices operating in explosive atmospheres Standard type	IEC 60079-0	EN 60079-0
Electric devices operating in explosive atmospheres flameproof "d"	IEC 60079-1	EN 60079-1
Electric devices operating in explosive atmospheres Increased safety "e"	IEC 60079-7	EN 60079-7

Construction

Electric motors are of totally enclosed, fancooled (blow-over) type. Cooling is provided by fans blowing external air over the ribbed outside surface (cooling system IC 411 according to IEC 34-6 or EN 60 034-6). Electric motors up to 225 frame size are made of grey cast iron. Motors frame sizes of 250 and more are made of welded housing and the terminal boxes of grey cast iron.

Materials							
Frame size	Stator		Shield	Terminal box	Flange	Fan's shield	Fan
	Stator frame	Feet	Material	Material	Material	Material	Material
71	Cast iron	Cast iron-screw on feet	Cast iron	Cast iron	Cast iron-screw on feet	Stell sheet-extruded	Plastic
80							
90							
100							
112							
132							
160	Cast iron	Cast iron-screw on feet	Stell sheet-welded	Stell sheet-welded	Stell sheet-welded	Stell sheet-welded	
180							
200							
225	Stell sheet-welded	Stell sheet-welded	Stell sheet-welded	Stell sheet-welded	Stell sheet-welded	Stell sheet-welded	
250							
280							
315							



Dimensions

Cast iron

Frame size:
71 mm

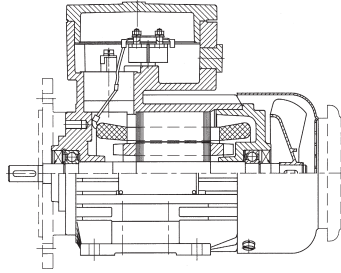

Cast iron

Frame size:
80 mm - 132 mm

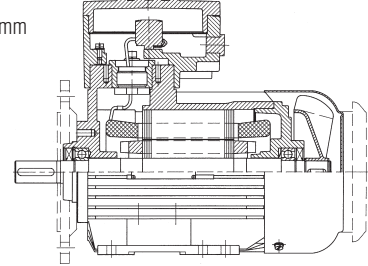

Cast iron

Frame size:
160 mm - 225 mm

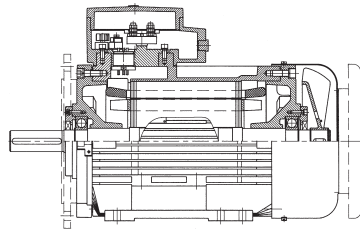

Welded

Frame size:
250 mm - 315 mm

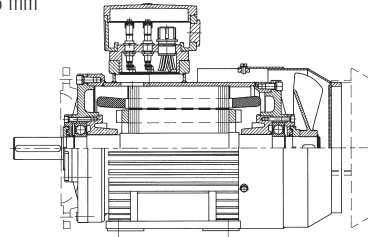

Type codes

Example

4KTC

132

SB

2/4

B5

Type

Frame size

Power rating (package length)

Number of poles (speed)

Customer - tailored version
on special request



Bearings

Bearing Lubrication

The following table lists the bearings used in the different motors. The bearings last about 20.000 hours in 4, 6 and 8 pole motors if the loads do not exceed the values indicated in the tables on pages 12 and 13.

Only the latest and most innovative bearings of known producers have been used in our motors. On customer request we equip the motors with other bearings (depends on the respective construction!).

The rotors are standard constructions and fixed on the D-end (frame size 71 mm to 160 mm) and B-end (frame size 180 mm to 225 mm).

Bearing

Frame size	Poles	DE bearing	NDE bearing	Bearing dishes
71	2 - 8	6203 2Z C3	6203 2Z C3	17 x 40 x 12
80	2 - 8	6204 2Z C3	6204 2Z C3	20 x 47 x 14
90	2 - 8	6205 2Z C3	6205 2Z C3	25 x 52 x 15
100	2 - 8	6206 2Z C3	6206 2Z C3	30 x 62 x 16
112	2 - 8	6206 2Z C3	6206 2Z C3	30 x 62 x 16
132	2 - 8	6208 2Z C3	6208 2Z C3	40 x 80 x 18
160	2 - 8	6309 2Z C3	6309 2Z C3	45 x 100 x 25
180	2 - 8	6310 2Z C3	6310 2Z C3	50 x 110 x 27
200	2 - 8	6312 2Z C3	6312 2Z C3	60 x 130 x 31
225	2 - 8	6313 2Z C3	6313 2Z C3	65 x 140 x 33
250	2 - 8	6314 2Z C3	6314 2Z C3	70 x 150 x 35
280	2 - 8	6316 2Z C3	6316 2Z C3	80 x 170 x 39
315	2 - 8	6317 2Z C3 *NU 317	6317 2Z C3	85 x 180 x 41

*on request:

* roller bearings from frame size 160

** isolated bearing from frame size 250

Bearing assemblies

	4KTC 71 - 132	4KTC 160 - 225	4KTC 250 - 315
Drive end			
Non-drive end			



Bearing Lubrication

Motors are normally fitted with permanently greased bearings of Type 2Z. According to experience the filled in grease will be sufficient for several years.

Motors fitted with grease nipples

Motors from frame size 160 and above can be fitted with regreasable bearings. For motors with lubrication system we recommend not to exceed lubrication interval of two years in any case. Lubricate the motor when operational. If the motor is fitted with a lubrication plate, use values given, or use values given in the table beside. These values are according to L1 – principle.

The effectiveness of motor lubrication should be checked by measuring the surface temperature of bearing endshield during normal operating conditions. If the measured temperature is +80 °C or above, the relubrication intervals must be shortened. Relubrication interval should be halffened for every 15K increase in bearing temperature. If this is not possible then use the lubricants suitable for high operation temperature conditions.

Ball Bearing: lubrication intervals in duty hours

Frame size	Amount of Grease [g]	Speed of the motor [min ⁻¹]					
		3600	3000	1800	1500	1000	500
160	25	7000	9500	14000	17000	21000	24000
180	30	6000	8000	13500	16000	20000	23000
200	40	4000	6000	11000	13000	17000	21000
225	50	3000	5000	10000	12500	16500	20000
250	60	2500	4000	9000	11500	15000	18000
280	70	2000	3500	8000	10500	14000	17000
315	90	2000	3500	6500	8500	12500	16000

Roller Bearing: lubrication intervals in duty hours

Frame size	Amount of Grease [g]	Speed of the motor [min ⁻¹]					
		3600	3000	1800	1500	1000	500
315	45	1000	1700	3000	4300	6000	8000

At an ambient temperature of ≤ 25 °C, twice the grease life can be expected, however, 33000 hours at a maximum.

In case of frequency converters and in continous operation at very low speeds, as well as at low temperature, the lubrication capabilities of standard greases may not be sufficient and special greases with additives are needed.

If motors are equipped with sealed bearings (i. e. bearings greased for life) any deviation in the operating temperature from design temperature will result in a change in lifetime of bearings.

The use of conductive greases for elimination of bearing currents is not recommended due to their poor lubrication characteristics and low conductivity.

Regreasing or replacement of greas is only allowed with grease quality of the same kind (same saponification component or consistency).



Shaft ends

The standard electric motor is equipped with one free shaft extension. On request we also supply versions with free shaft extensions on both sides.

The dimensions of the shaft ends correspond to the IEC 60072 (1971) standard, fifth edition. Tolerances for shaft end-diameters are in accordance with DIN 7154:

- up to diameter of 50 mm/ISO k6
- more than 50 mm/ISO m6

Free shaft extensions are equipped with keyways. Keyway and key correspond to DIN 6885.

The shafts have a threaded central hole for the drawing in, drawing out and fixing connections.

Shaft diameter	14 mm	19 mm	24 mm	28 mm	38 mm	from 42 to 48 mm	from 55 to 80 mm	from 90 to 100 mm
	M5	M6	M8	M10	M12	M16	M20	M24

Permissible loads on free shaft end

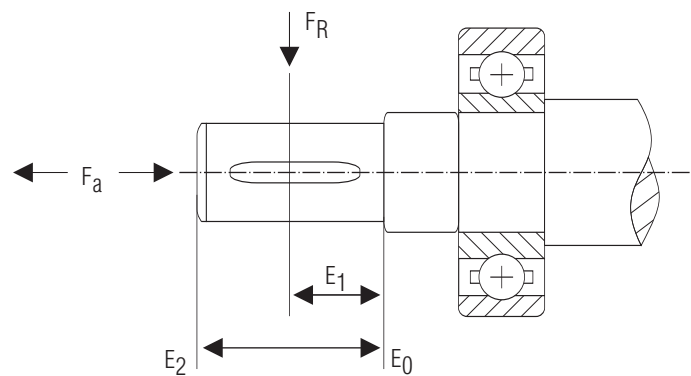



Allowable radial force

Frame size	Number of poles	Radial force F_R [kN]		
		E_0	E_1	E_2
71	2	0.48	0.43	0.39
	4	0.6	0.54	0.5
	6	0.69	0.62	0.56
	8	0.76	0.68	0.62
80	2	0.64	0.57	0.51
	4	0.81	0.72	0.65
	6	0.93	0.83	0.74
	8	1.02	0.91	0.82
90	2	0.72	0.64	0.57
	4	0.9	0.8	0.71
	6	1.04	0.92	0.82
	8	1.14	1.01	0.9
100	2	1.01	0.9	0.81
	4	1.28	1.15	1.04
	6	1.45	1.3	1.17
	8	1.61	1.43	1.3
112	2	0.99	0.87	0.79
	4	1.23	1.09	1.08
	6	1.42	1.25	1.12
	8	1.57	1.39	1.24
132	2	1.56	1.38	1.23
	4	1.96	1.78	1.55
	6	2.24	1.98	1.77
	8	2.45	2.16	1.96
160	2	2.99	2.63	2.35
	4	3.83	3.38	3.02
	6	4.33	3.81	3.4
	8	4.79	4.22	3.78
180	2	3.55	3.14	2.84
	4	4.43	3.82	3.53
	6	5.1	4.52	4.08
	8	5.63	5.0	4.52
200	2	4.33	4.24	3.6
	4	4.45	4.95	4.52
	6	6.28	5.71	5.23
	8	6.88	6.25	5.72
225	2	10.4	9.45	8.32
	4	13.1	11.65	10.49
	6	15.03	13.37	12.03
	8	16.6	14.78	13.3
250	2	11.64	10.41	9.4
	4	14.77	13.22	11.96
	6	16.97	15.2	13.75
	8	18.73	16.78	15.19
280	2	14.52	13.03	11.8
	4	18.18	16.31	14.76
	6	20.93	18.78	17.02
	8	22.93	20.56	18.62
315	2	16.55	14.92	13.57
	4	20.62	18.57	16.86
	6	19.73	17.58	15.82
	8	21.93	19.56	17.62



Maximum axial loads, noise level and vibration

Maximum loads for free shaft extension Fa[kN]																
Mounting arrangements	IM B7 IM B3				IM B8 IM B35				IM B14 IM B5				IM B34 IMJ B6			
	IM V18 IM V19 IM V1 IM V3 IM V5 IM V6								Weight of rotor in load direction				Weight of rotor in opposite load direction			
	3000	1500	1000	750	3000	1500	1000	750	3000	1500	1000	750				
71	0.27	0.34	0.39	0.43	0.33	0.43	0.47	0.52	0.35	0.46	0.51	0.55				
80	0.36	0.45	0.52	0.57	0.43	0.55	0.62	0.69	0.47	0.6	0.69	0.76				
90	0.41	0.51	0.59	0.65	0.48	0.61	0.69	0.77	0.54	0.68	0.79	0.86				
100	0.55	0.69	0.79	0.88	0.64	0.81	0.92	1.03	0.75	0.94	1.07	1.11				
112	0.55	0.69	0.79	0.88	0.63	0.77	0.89	1.0	0.76	0.98	1.1	1.14				
132	0.83	1.04	1.2	1.32	0.92	1.13	1.3	1.48	1.16	1.47	1.67	1.82				
160	1.52	1.91	2.19	2.41	1.65	2.1	2.4	2.65	2.13	2.68	3.08	3.31				
180	1.77	2.24	2.56	2.82	1.85	2.3	2.71	3.0	2.55	3.26	3.74	4.13				
200	2.33	2.94	3.37	3.71	2.39	3.06	3.54	3.89	3.45	4.38	4.91	5.5				
225	2.66	3.36	3.85	4.23	2.71	3.3	3.78	4.25	4.03	5.05	5.94	6.28				
250	2.98	3.76	4.30	4.73	2.92	3.85	4.07	4.48	4.62	5.55	6.81	7.46				
280	3.50	4.41	5.05	5.56	3.18	3.76	4.52	4.82	5.51	7.13	7.94	8.89				
315	3.58	4.51	5.17	5.69	2.33	2.31	2.01	2.55	6.09	8.15	9.34	10.05				

The load rating of bearings has been calculated for at least 20 000 operating hours at a frequency of 50 Hz. Only the axial loads have been considered. If the load is made up of axial and radial loads, the working life of the bearings is shorter.



Noise level and vibrations

Maximum noise level L dB allowed at 1 m distance from the machine surface Values for fan-cooled (blow-over) machines; IP 44

Power ratings P (kW)	Rotation speed min ⁻¹					
	600 < n ≤ 960	960 < n ≤ 1320	1320 < n ≤ 1900	1900 < n ≤ 2360	2360 < n ≤ 3150	3150 < n ≤ 3750
P ≤ 1.1	67	70	71	74	75	79
1.1 < P ≤ 2.2	69	70	73	78	80	82
2.1 < P ≤ 5.5	72	74	77	82	83	85
5.5 < P ≤ 11	75	78	81	86	87	90
11 < P ≤ 22	78	82	85	87	91	93
22 < P ≤ 37	80	84	86	89	92	95
37 < P ≤ 55	81	86	88	92	94	97
55 < P ≤ 110	84	89	92	93	96	98
110 < P ≤ 220	87	91	94	96	98	100

Noise level and vibrations

The noise level of electric motors is below the limits prescribed by the IEC 60034-9 recommendation for fan-cooled (blow-over) electric machines.

The rotors of electric motors are dynamically balanced with installed fan and 1/2 key. Vibration amplitude corresponds to N grade (normal) according to IEC 60034-14 (ISO 2373-N grade).

Limit values for the vibration of electric machines (IEC 34-14; DIN ISO 2373)

Degree	Rotation speed min ⁻¹	Limits of V _{ef} in mm/s		
		80 up to 132	160 up to 225	230 up to 315
N (normal)	600 to 1 800 nad 1 800 to 3 600	1.8	2.8	3.5
R (reduced)	600 to 1 800 nad 1 800 to 3 600	0.71 1.12	1.12 1.8	1.8 2.8
S (special)	600 to 1 800 nad 1 800 to 3 600	0.45 0.71	0.71 1.12	1.12 1.8

The vibration level is the maximum r. m. s. value of vibration velocity in a frequency range from 10 Hz to 1 000 Hz.

Measured according to DIN ISO 2373, IEC 60034-14



Terminal box and terminals for supply cable

Terminal box

The terminal box is fitted to the top of the motor with the cable entering from the fan end of the motor. It can be repositioned in steps of 90° to 180° to suit the application.

The motors with direct starting are equipped with 3 connection terminals. 6 connection terminals are fitted to Star-Delta, two speed and dual voltage machines.

The electric motors with sizes 71 to 132 inclusive and EEx e terminal boxes have 6 additional connection terminals for PTC sensors, heaters etc. The motors with EEx d terminal boxes are also equipped with 6 connection terminals. Exception is the 71 motor with only 4 connection terminals.

Each terminal box has one connection terminal for the protective conductor.

EEx d terminal boxes include a threaded entry to accept EEx d cable glands (see table below). EEx d thread reducers or adaptors can be included as an option for other thread sizes and thread forms.

Terminals for supply cable and cable entries				
Frame size	Terminals for a max. cross section of supply cable (mm ²)	Cable entries for main connection		
		EEx e terminal box		EEx d terminal box
		Cable entries	External diameter of supply cable (mm)	Cable entries
71	2.5	1 x M20 x 1.5	6.5 to 12	1 x M20 x 1.5
80 90 100	4	1 x M25 x 1.5	13 to 18	1 x M25 x 1.5
112	4	1 x M32 x 1.5	13 to 18	1 x M32 x 1.5
132	4	2 x M32 x 1.5	13 to 18	2 x M32 x 1.5
160 180	16	2 x M40 x 1.5	22 to 32	2 x M40 x 1.5
200 225	16	2 x M50 x 1.5	32 to 38	2 x M50 x 1.5
250 280 315	95 - 300	2 x M63 x 1.5	37 to 44	2 x M63 x 1.5

* Additional one cable entry (gland) M20 x 1.5 for PTC

Increased safety terminal boxes include EEx e cable glands in accordance with EN 60079-0, and EN 60079-7.

The empty entries are fitted with suitably certified stopping plugs. Additional entries can only be made in our factory under strict quality procedures.

The EEx d terminal may receive additional threaded holes (NPT, ISO 7/1) by means of adapters.

One threaded hole M20 x 1.5 is provided on the EEx d terminal boxes for the thermal protection and for heaters. EEx e terminal boxes have an additional cable gland M20 x 1.5 for cable diameters of 6 to 12 mm.



EEx e version 4 KTC

Frame size:
71 mm

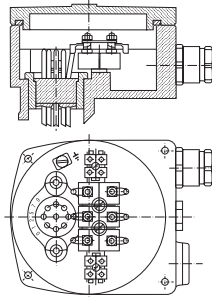

Frame size:
80 mm -
132 mm

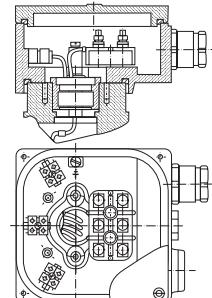

Frame size:
160 mm -
225 mm

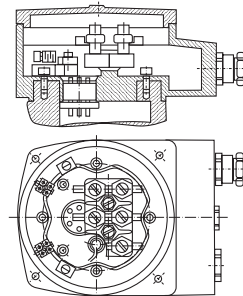

Frame size:
250 mm -
315 mm

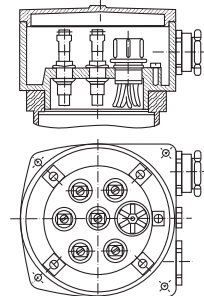

EEx d version 4 KTC

Frame size:
71 mm

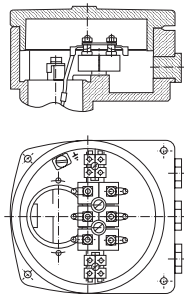

Frame size:
80 mm -
132 mm

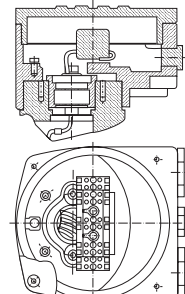

Frame size:
160 mm -
225 mm

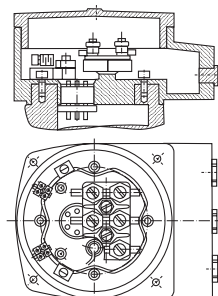

Frame size:
250 mm -
315 mm

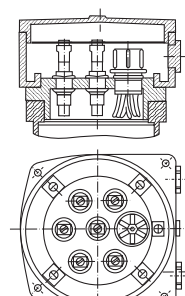



Degrees of IP protection and coating

IP protection

IP protection of electric motors corresponds to IP 55. Motors with a higher degree of IP protection are manufactured on special request.

Protection against environmental influences IP protection

Protection class	Protection against harmful contact and ingress of solids (1st Numeral)
IP 44	Protection against direct contact with electrically live and rotating inner parts using tools, wire or similar objects with a diameter exceeding 1 mm. Protection against ingress of solids (diameter > 1 mm). Fan air outlets and water exhausts may have a second-degree level of protection.
IP 54/IP 55/IP 56	Complete protection against contact with electrically live and moving rotating inner parts. Protection against harmful ingress of dust. Ingress of dust is not fully prevented, but must not reach an extend causing harmful effects to machine operation.
IP 65*	Complete protection against contact with electrically live parts and rotating inner parts. Protection against ingress of dust (dust-proof machine).

Protection class	Protection against ingress of water (2nd Numeral)
IP 44/IP 54	Water particles spraying from any direction do not have any harmful effects on the machine (i. e. rain).
IP 55/IP 65*	A jet of water spraying from any direction does not have any harmful effects on the machine.
IP 56	During rough seas water must not penetrate into the interior of the motor to such an extend as to cause damage to the machine (deck-mounted motors).

*All vertically-mounted electric motors with free shaft extension on the top must be protected against particles falling into the fan cover. This protection is not necessary if the machine itself has such a protection. Electric motors mounted outdoors must be protected against exposure to direct sunlight.

Coating

Surface protection against aggressive environmental influences

	Anti-corrosion protection 2 (standard)	Anti-corrosion protection 3 (special)	Special surface protection
Surface	sanding and degreasing	sanding and degreasing	Products with surface protection against chemical influences and tropical conditions are available on special request.
Undercoating	Alkyd	Epoxy	
Coating	-	Epoxy	
Finishing	Alkyd (2 x)	Epoxy	
Total thickness μm	80	140	
Colour*	blue RAL 5010	blue RAL 5010	
Protection against corrosion in environments with water	high humidity, steam, sea water	high humidity, steam, sea water	
Environmental resistance	periodic spilling or spraying of anorganic acids and lyes	periodic spilling or spraying of anorganic acids and lyes	
Temperature resistance	-40 °C to +130 °C	-40 °C to +130 °C	
Suitable for	normal industrial atmospheres, relatively high humidity and high concent of salt and aggressive gases (SO ₂ , NO _x)	Chemically aggressive atmospheres, high concent. of salt and aggres. gases (SO ₂ , NO _x). Condensation of moisture and electrolytes on surface. Solvents and oil derivates have negative effects.	

* Mining industry: yellow RAL 1003 for 500 V, grey RAL 9003 for 1000 V



Arrangements

The types of electric motors and their symbols are prescribed by the IEC 60 034-7, EN 60 034-7 standards. Motors are manufactured following the basic IM B3, IM B5 and IM B14 types.

Table 4 shows the symbols and mounting arrangements for the standard models manufactured by our company. IM B3 type motors can also operate in IM B6, IM B7 and IM B8 mounting positions.

IEC code I	IM B3	IM B5	IM B34	IM B14	IM B35
IEC code II	IM 1001	IM 3001	IM 2101	IM 3601	IM 2001
IEC code I	IM V6	IM V3	IM V6/IM V19	IM V19	IM V36
IEC code II	IM 1031	IM 3031		IM 3631	IM 2031
IEC code I	IM V5	IM V1	IM V5/IM V18	IM V18	IM V15
IEC code II	IM 1011	IM 3011		IM 3611	IM 2011

Explosion protection and certifications

Explosion protection

Explosion protection markings are

- frame size 71 to 160 II 2G EEx d IIC T4 or II 2G EEx de IIC T4
 II 2D IP 6X T 135 °C
- frame size 180 to 315 II 2G EEx d IIC T4 or II 2G EEx de IIC T4

Certifications

4 KTC-type motors are PTB-certified (Physikalisch-technische Bundesanstalt), Germany:

- PTB 99 ATEX 1005 frame sizes 80 to 132
- PTB 99 ATEX 1138 frame sizes 71 and 160
- PTB 05 ATEX 1054 frame size 180
- PTB 05 ATEX 1099 frame size 200
- PTB 05 ATEX 1100 frame size 225
- PTB 03 ATEX 1127 frame size 250
- PTB 03 ATEX 1141 frame size 280
- PTB 03 ATEX 1126 frame size 315



Electric system

Power, voltage and frequency

The power ratings given in the tables are valid for operation under uniform, continuous load (S-1 according to IEC 60034-1, EN 60034-1) at a rated voltage, a frequency of 50 Hz, temperatures of up to +40 °C and an altitude of less than 1 000 m above sea level. The data in the tables refer to 400 V, but motors have been designed for 380 V and 415 V.

Voltage or frequency variations of +/- 5 % are allowed; within these limits the power ratings remain unchanged and the maximum winding temperature is not exceeded.

Versions using 110 V to 1 000 V and frequencies of 50 or 60 Hz are available on special request. 50 Hz, 380 V, 400 V, 415 V electric motors may also be connected to 440 V - 480 V and a frequency of 60 Hz. Then the maximum load can be increased by 15 % and the number of revolutions by approximately 20 %.

If a 50 Hz, 380 V, 400 V, 415 V electric motor is connected to a 60 Hz line, its maximum load may not exceed the nominal power. The number of revolutions increases by 20 %, while the starting and maximum torque decreases by approx. 18 %.

Overload, efficiency and power factor

Electric motors heated to the operating temperature limit resist to a 2-minute overload of 1.5 In without being damaged. Variations between the 5/4 and 3/4 of the rated load have no essential influence on efficiency and power factor.

Efficiency η (%) of the rate load			
5/4	4/4	3/4	2/4
96	96	96	94.5
95	95	95	93.3
94	94	94	92
93	93	93	91
92	92	92	90
91	91	91	89
90	90	90	87
89	89	89	86
88	88	83	85.5
86	87	87	85
85	86	86	84.5
84	85	85	84
83	84	84	83
82	83	83	81
81	82	82	80.5
79	81	81	80
78	80	80	79
77	79	79	78
76	78	78	76
75	77	77	75
74	76	76	74
73	75	75	73
72	74	74	72
71	73	73	71
70	72	72	69
69	71	71	68
68	70	70	67
67	69	69	66
66	68	67.5	64
65	67	66.5	62
64	66	65	61

Power factor $\cos \varphi$ of the rate load			
5/4	4/4	3/4	2/4
0.94	0.94	0.92	0.74
0.94	0.93	0.92	0.68
0.92	0.92	0.89	0.65
0.91	0.91	0.88	0.64
0.9	0.9	0.87	0.63
0.89	0.89	0.88	0.6
0.88	0.88	0.85	0.58
0.88	0.87	0.84	0.57
0.87	0.86	0.83	0.55
0.86	0.85	0.82	0.53
0.86	0.84	0.81	0.51
0.85	0.83	0.8	0.49
0.85	0.82	0.78	0.47
0.83	0.81	0.76	0.45
0.82	0.8	0.75	0.43
0.82	0.79	0.73	0.42
0.79	0.78	0.73	0.41
0.78	0.77	0.72	0.4
0.78	0.76	0.7	0.38
0.77	0.75	0.69	0.36
0.76	0.74	0.67	0.36
0.75	0.73	0.66	0.35
0.74	0.72	0.65	0.34
0.73	0.71	0.64	0.34
0.72	0.7	0.63	0.33
0.71	0.69	0.62	0.33
0.7	0.68	0.61	0.32
0.7	0.67	0.59	0.3
0.68	0.66	0.57	0.3
0.68	0.65	0.55	0.3
0.67	0.64	0.54	0.3



Windings

Materials of thermal class F are used for the production of stator windings. They are designed to withstand an overtemperature of 80 K at a maximum ambient temperature of 40 °C. Electric motors operating under heavy conditions, conditions requiring frequent start-ups or ambient temperatures above 40 °C employ special insulation (thermal class H) and are available on special request. Windings of electric motors rated up to 3 kW are connected via star, while those of high-rated motors employ delta connection. Two-speed motors with 2:1 speed ratio use Dahlander windings. Electric motors with a pole relation of 4/6 or 8/6 have two separate stator windings in star connection.

Wiring diagram	EEx d	EEx e	EEx d and EEx e terminal box	EEx d	EEx e
Single speed Start with Y-D switch, remove Y-D jumper					
	Y-D-jumper in Y-connection for direct coupling		Y-D-jumper in D-connection for direct coupling		
Pole-changing					
	Low speed		High speed		
Pole-changing (Dahlander)					
	Low speed		High speed		
Pole-changing (Dahlander)					
	Low speed		High speed		

Installation instructions

for the mains connection and start-up of motors with EEx d terminal box.

Connect the motors via suitable cable and line entries that correspond to the EN 5018-1977 directives, paragraphs 12.1 and 12.2 and have a separate test certificate. Unused openings must be closed as prescribed by EN 50018-1977, paragraph 12.5. Cable and line entries (heavy-gauge conduit threads) and sealing plugs that do not meet these requirements must not be used.



Test and tolerance band of the rated values

Electric motors are tested in accordance with IEC 60034-2, EN 60034-2 regulations. All nominal and start-up value deviations are within the limits prescribed by IEC 60034-1, EN 60034-1.

The explosion-proof enclosure is tested according to the IEC 60034-1, EN 60034-1 regulations. All enclosure parts are tested with a water pressure of 1 000 kPa.

Rated values under extreme working conditions

When electric motors are used at temperatures above +40 °C or at altitudes of more than 1 000 m, the permitted overtemperature for windings is lower; the rated power is reduced respectively. The relation between rated power and ambient temperature altitude is shown in the diagrams.

Tolerances of rated values

The rated values shown in the tables may vary according to IEC 60 034-1, EN 60 034-1.

Performance

Rated power ≤ 50 kW	- 0.15 (1-η)
> 50 kW	- 0.10 (1-η)
Power factor	- $\frac{1 - \cos \varphi}{6}$
Slip at rated load and machine heated to operating temperature	+ 20 % of rated slip
Starting torque	- 15 % of rated value + 25 %
Maximum torque	- 10 % of rated value
Starting current	+ 20 % lower limit not prescribed

Power reduction as temperatures rise

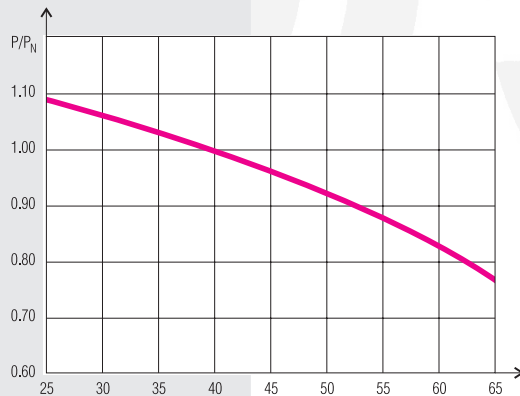

Power reduction at less cooling

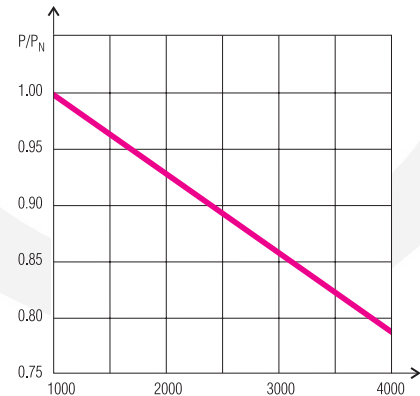



Start-up characteristics

Start-up torque and current are the actual values the motor develops and the current values that cross the power supply cable when voltage is applied to the electric motor. The charts below show the values for both start-up torque and peak torque as well as the start-up current given as multiple of the nominal values.

Motor torque classification

For the right choice of the motor you not only have to know starting and maximum torque but also the torque curve and speed. To avoid the plotting of torque curves which are unique for each type of motor, the rotor torque class is defined as one of the electric motor's characteristics. This way the suitable motor can be chosen without the (exact) knowledge of the course of the torque curve.

The motor torque class shows the maximum counter-torque for starting the motor. The starting torque class is specified according to the nominal voltage. In this catalog we distinguish three classes:

KR 10

KR 13

KR 16

The titles of the torque classes contain numbers which correspond to one tenth (1/10) of the maximum counter-torque value necessary to start up the motor. The following illustrations represent the torque curves of the classes KR 10, KR 13 and KR 16.

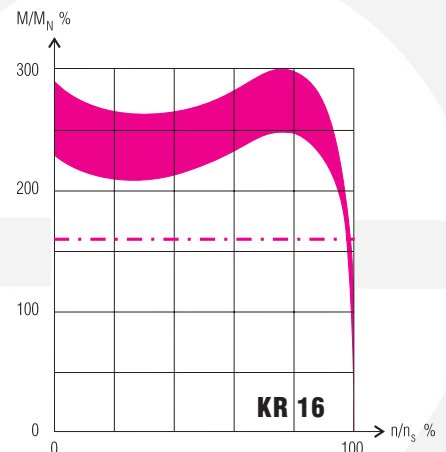
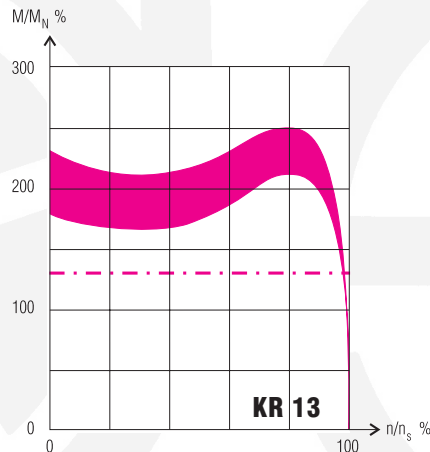
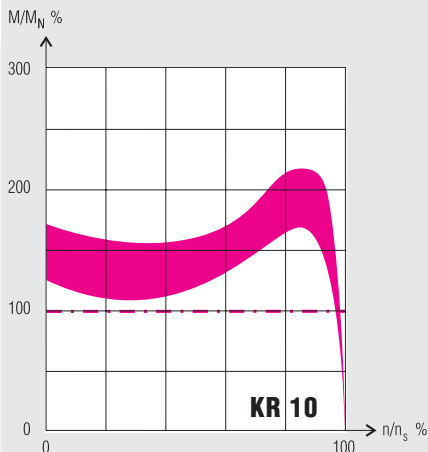



Duty cycles

S1 Continuous duty

Operation under constant load, lasting long enough to allow the machine to reach thermal equilibrium.

Designation: **S1**

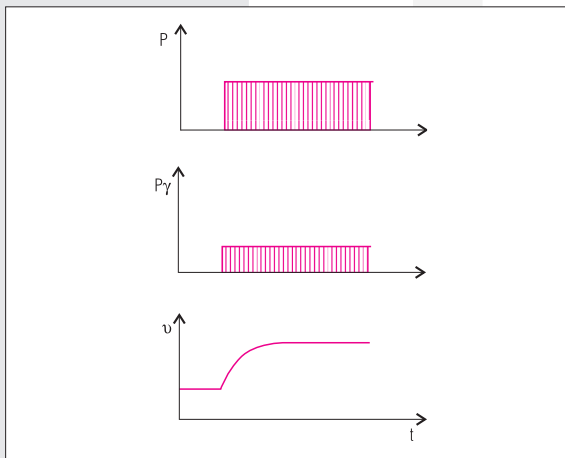

S2 Short-time duty

Operation under constant load, for a time too short to allow the machine to reach thermal equilibrium. Idle time of the machine is long enough to allow the machine to cool down to ambient temperature.

Standard duration of short-term operation: 10, 30, 60 and 90 minutes.

Designation: **S2** 30 minutes.

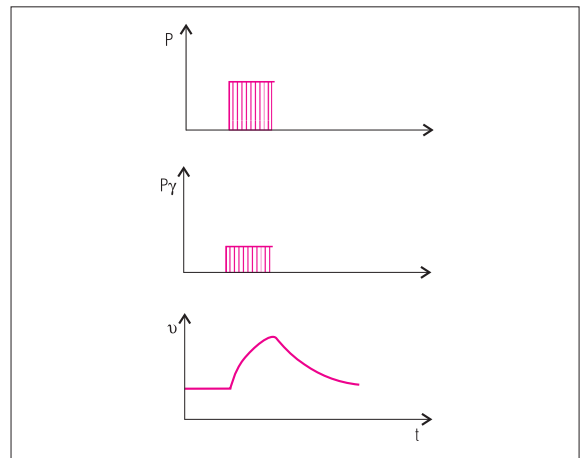

S3 Intermittent periodic duty

Operation under repeated, constant load in specified cycles. Neither operating nor resting period are long enough to allow the motor to reach thermal equilibrium. The starting losses are small and do not essentially influence the temperature rise. The nominal values of relative starting time are 15, 25, 40, 60 % at a daily 10-minute cycle.

Designation: **S3** 25 %

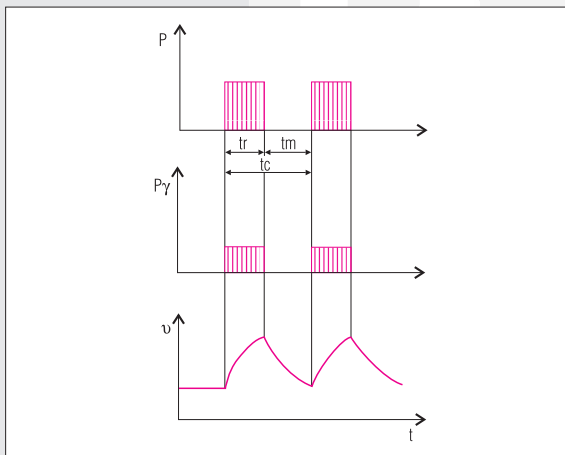

S4 Intermittent periodic duty

Operation under repeated, constant load in specified cycles. The start of the motor influences the temperature rise.

In order to define this type of operation, the number of cycles (starts per hour) and inertia constant must also be known.

Designation: **S4** 40 %; 120 starts/h; FI2

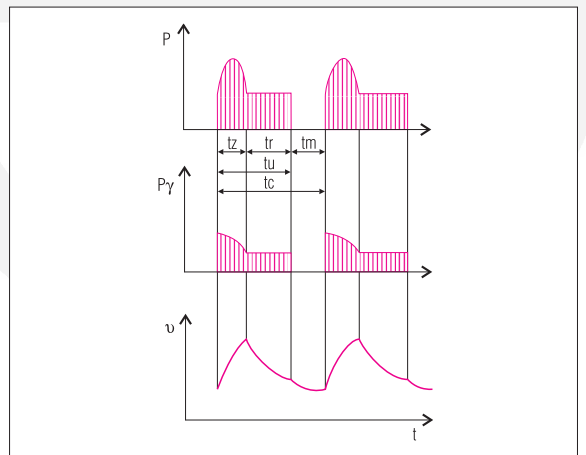

S5 Intermittent periodic duty

Same as S4 operation, except that the electric braking of the machine has an essential influence on the temperature rise.

Designation: **S5** 160 %; 120 starts/h; F12

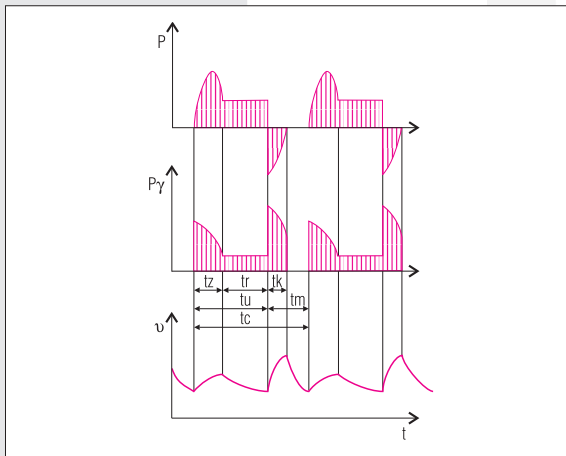

S6 Continuous operation with cyclic load

Operation consisting of a continuous series of equal cycles. Each cycle is made up of a no-load and a constant load period.

The cycle duration is not long enough to allow the machine to reach thermal equilibrium in one cycle.

In order to define S6 operation, the relative starting time must be specified.

Designation: **S6** 15 %

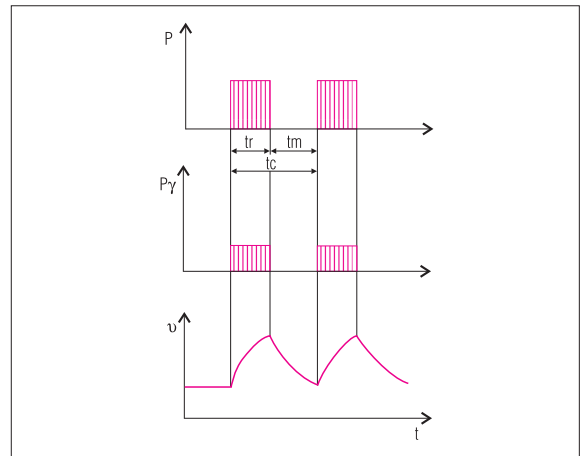

S7 Intermittent periodic duty with starting and braking

Uninterrupted operation with a series of constant loading and braking periods. The most demanding type of operation for the motor. In order to define this type of operation, the number of cycles per hour and the inertia constant must be specified.

Designation: **S7** 500 starts/h; F13

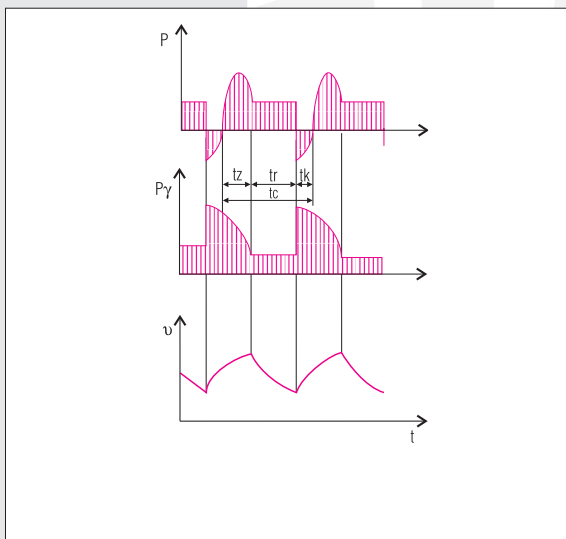

S8 Intermittent periodic duty with pole changing

This type of operation only exists with pole amplitude modulated motors. In this case the definition of operation must contain the following data for each pole:

- number of starts per hour
- inertia constant
- relative operating period

Designation: **S8** 30 starts/h; F110; 740 min⁻¹; 40 %

S8 30 starts/h; F110; 960 min⁻¹; 60 %

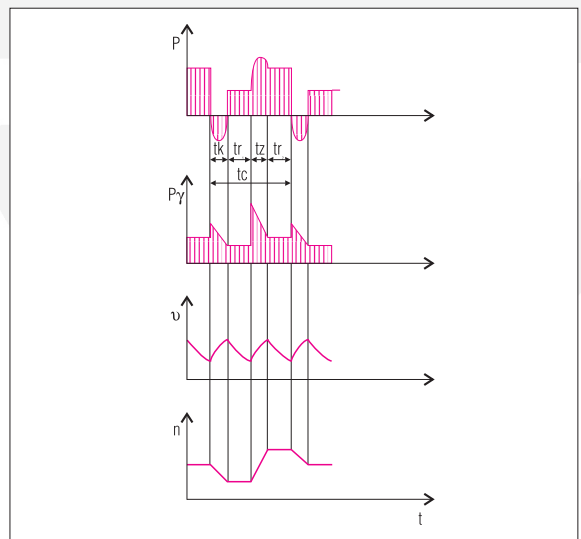

S9 Continuous operation with non-periodic load and speed variation

(e. g. converter operation)



Tables with ratings for single-speed motors - 50 Hz

Three-phase motor with short-circuit rotor

Pole number 2

220 - 240 V / 380 - 415 V 50 Hz
380 - 415 V / 660 - 690 V 50 Hz

Protection class IP 55
Temperature class T1 - T4
Thermal class F

Explosion protection													
	Type 4KTC or 4KTCD						Type 4KTC			Type 4KTC			
	71	80	90	100	112	132	160	180	200	225	250	280	315
PTB 99 ATEX 1138	●												
PTB 99 ATEX 1005		●	●	●	●	●							
PTB 00 ATEX 1080													
PTB 05 ATEX 1054								●					
PTB 05 ATEX 1099									●				
PTB 05 ATEX 1100										●			
PTB 03 ATEX 1127											●		
PTB 03 ATEX 1141												●	
PTB 03 ATEX 1126													●

Selection chart

Type	Power kW	Speed min ⁻¹	In 400 V A	Efficiency %	Power factor cos φ	Torque Nm	Starting torque (MA/MN)	Starting current (IA/IN)	Max. torque (MM/MN)	KR	Moment of inertia (kgm ²)	Weight kg
4KTC 71 A-2	0.37	2820	0.98	67.2	0.81	1.25	3	5.4	3.2	16	0.00034	15
4KTC 71 B-2	0.55	2800	1.28	72.7	0.86	1.88	2.8	5.4	3.1	16	0.00042	16
4KTC 80 A-2	0.75	2810	1.61	77.5	0.87	2.55	2.6	4.9	2.8	16	0.00063	24
4KTC 80 B-2	1.1	2775	2.29	78.8	0.88	3.78	2.8	5.1	2.9	16	0.00079	26
4KTC 90 S-2	1.5	2855	3.07	81.6	0.86	5.0	2.8	6.1	3.1	16	0.00124	32
4KTC 90 L-2	2.2	2845	4.4	80.8	0.89	7.4	2.7	5.9	2.7	16	0.00155	34
4KTC 100 L-2	3.0	2875	6.4	79.5	0.85	10.0	3.0	5.7	3.3	16	0.00251	42.5
4KTC 112 M-2	4.0	2880	7.8	84.0	0.88	13.3	2.7	6.9	3.1	16	0.00451	58
4KTC 132 SA-2	5.5	2910	10.4	87.0	0.88	18.1	2.6	6.3	3.0	16	0.00967	77
4KTC 132 SB-2	7.5	2920	14.1	87.7	0.88	24.5	3.0	6.9	3.3	16	0.01225	84
4KTC 160 MA-2	11.0	2940	20.6	89.4	0.86	35.8	3.8	7.9	3.3	16	0.02943	148
4KTC 160 MB-2	15.0	2940	26.5	90.6	0.9	48.7	3.4	7.9	3.0	16	0.03912	166
4KTC 160 L-2	18.5	2945	32.2	91.6	0.91	60.0	3.1	7.4	3.1	16	0.0459	178
4KTC 180 M-2	22.0	2940	41.3	84.2	0.91	71.5	2.8	6.9	2.9	16	0.06151	205
4KTC 200 LA-2	30.0	2955	54.4	88.5	0.9	97.0	2.4	6.9	2.6	16	0.10442	240
4KTC 200 LB-2	37.0	2970	66.5	88.6	0.91	119.1	3.3	9.0	3.0	16	0.12739	250
4KTC 225 M-2	45.0	2970	82.0	89.6	0.88	145.0	2.5	7.6	3.4	16	0.22155	375
4KTC 250 M-2	55.0	2970	98.0	89.3	0.91	177.0	2.1	6.6	2.2	16	0.675	485
4KTC 280 S-2	75.0	2980	136.0	90.8	0.88	241.0	3.0	8.3	2.7	16	0.95	650
4KTC 280 M-2	90.0	2980	158.0	91.5	0.9	289.0	3.0	8.1	2.6	16	1.1	700
4KTC 315 S-2	110.0	2970	186.0	91.5	0.94	353.0	2.5	7.2	3.1	13	1.55	820
4KTC 315 MA-2	132.0	2985	223.0	92.1	0.93	425.0	2.8	7.5	2.8	13	1.8	930
4KTC 315 MB-2	160.0	2975	272.4	90.1	0.94	515	2.9	8.1	3.1	13	2.2	1240
4KTC 315 L-2	200.0	2980	345.0	93.0	0.90	640	2.3	6.9	2.6	13	2.8	1380



Three-phase motor with short-circuit rotor

Pole number 4

220 - 240 V / 380 - 415 V 50 Hz
380 - 415 V / 660 - 690 V 50 Hz

Protection class IP 55
Temperature class T1 - T4
Thermal class F

Explosion protection													
Certificate	Type 4KTC or 4KTCD						Type 4KTC			Type 4KTC			
	71	80	90	100	112	132	160	180	200	225	250	280	315
PTB 99 ATEX 1138	●						●						
PTB 99 ATEX 1005		●	●	●	●	●							
PTB 00 ATEX 1080													
PTB 05 ATEX 1054								●					
PTB 05 ATEX 1099									●				
PTB 05 ATEX 1100										●			
PTB 03 ATEX 1127												●	
PTB 03 ATEX 1141													●
PTB 03 ATEX 1126													●

Selection chart

Type	Power kW	Speed min ⁻¹	In 400 V A	Efficiency %	Power factor cos φ	Torque Nm	Starting torque (MA/MN)	Starting current (IA/IN)	Max. torque (MM/MN)	KR	Moment of inertia (kgm ²)	Weight kg
4KTC 71 A-4	0.25	1370	0.69	67.0	0.78	1.74	2.15	3.8	2.2	16	0.00051	15
4KTC 71 B-4	0.37	1385	0.95	72.5	0.78	2.55	2.15	4.0	2.3	16	0.00063	16
4KTC 80 A-4	0.55	1400	1.34	76.9	0.77	3.76	2.3	4.4	2.4	16	0.00098	24
4KTC 80 B-4	0.75	1410	1.7	82.4	0.77	5.1	2.6	5.0	2.7	16	0.00125	26
4KTC 90 S-4	1.1	1410	2.4	80.9	0.82	7.5	2.15	4.8	2.5	16	0.00204	32
4KTC 90 L-4	1.5	1415	3.35	80.6	0.8	10.1	2.5	5.2	2.8	16	0.0026	35
4KTC 100 LA-4	2.2	1410	4.7	81.5	0.82	14.9	2.0	4.6	2.5	16	0.00388	42.5
4KTC 100 LB-4	3.0	1415	6.5	79.6	0.83	20.2	2.1	5.0	2.6	16	0.00499	46
4KTC 112 M-4	4.0	1435	8.3	85.4	0.81	26.6	2.8	6.1	3.1	16	0.01014	60
4KTC 132 S-4	5.5	1435	10.8	86.0	0.85	36.6	2.2	5.1	2.4	16	0.02113	84
4KTC 132 M-4	7.5	1445	14.5	88.9	0.84	49.5	2.5	6.0	2.8	16	0.02793	93.5
4KTC 160 M-4	11.0	1460	22.0	87.1	0.83	71.8	2.9	6.9	3.1	16	0.05417	159
4KTC 160 L-4	15.0	1465	29.0	90.8	0.83	97.8	3.1	7.4	3.0	16	0.07116	178
4KTC 180 M-4	18.5	1465	35.0	89.9	0.86	120.6	3.1	6.9	2.5	16	0.1129	215
4KTC 180 L-4	22.0	1470	40.5	90.9	0.86	143.2	3.1	7.1	2.6	16	0.1339	236
4KTC 200 L-4	30.0	1470	53.4	89.6	0.91	195.1	2.7	6.8	2.8	16	0.21298	250
4KTC 225 S-4	37.0	1475	66.6	92.2	0.87	239.7	2.9	7.0	2.4	16	0.36225	310
4KTC 225 M-4	45.0	1475	80.5	92.5	0.87	291.0	3.3	7.3	2.7	16	0.42845	390
4KTC 250 M-4	55.0	1480	98.0	92.5	0.89	355.0	3.4	7.7	2.7	16	0.875	480
4KTC 280 S-4	75.0	1485	138.0	92.2	0.84	482.0	3.0	7.6	2.4	16	1.875	610
4KTC 280 M-4	90.0	1490	166.0	93.5	0.84	578.0	2.8	7.8	2.6	16	2.25	685
4KTC 315 S-4	110.0	1485	207.0	90.7	0.84	706.0	2.6	6.3	2.5	16	3.5	820
4KTC 315 MA-4	132.0	1485	235.0	92.2	0.88	851.0	3.0	6.9	2.5	16	3.875	930
4KTC 315 MB-4	160.0	1490	298.0	92.5	0.84	1027	1.9	5.8	2.1	16	5	1240
4KTC 315 L-4	200.0	1485	351.5	93.0	0.88	1285	1.5	6.8	1.6	16	6.1	1380



Three-phase motor with short-circuit rotor

Pole number 6

220 - 240 V / 380 - 415 V 50 Hz
380 - 415 V / 660 - 690 V 50 Hz

Protection class IP 55
Temperature class T1 - T4
Thermal class F

Explosion protection	II 2G EEx d IIC T4, II 2G EEx de IIC T4 II 2D IP6X T 135° C												
Certificate	Type 4KTC or 4KTCD			Type 4KTC			Type 4KTC						
	71	80	90	100	112	132	160	180	200	225	250	280	315
PTB 99 ATEX 1138	●						●						
PTB 99 ATEX 1005		●	●	●	●	●							
PTB 00 ATEX 1080													
PTB 05 ATEX 1054								●					
PTB 05 ATEX 1099									●				
PTB 05 ATEX 1100										●			
PTB 03 ATEX 1127												●	
PTB 03 ATEX 1141													●
PTB 03 ATEX 1126													●

Selection chart													
Type	Power	Speed	In	Efficiency	Power	Torque	Starting	Starting	Max.	KR	Moment	Weight	
	kW	min ⁻¹	400 V A	%	factor cos φ	Nm	torque (MA/MN)	current (IA/IN)	torque (MM/MN)		of inertia (kgm ²)	kg	
4KTC 71 A-6	0.18	930	0.67	60.0	0.65	1.86	2.1	3.1	2.3	16	0.00081	15	
4KTC 71 B-6	0.25	940	0.85	64.0	0.67	2.56	2.2	3.7	2.5	16	0.00101	16	
4KTC 80 A-6	0.37	925	1.1	67.0	0.72	3.83	2.3	3.6	2.5	16	0.00191	25	
4KTC 80 B-6	0.55	915	1.5	72.0	0.74	5.7	2.35	4.1	2.5	16	0.00239	26.5	
4KTC 90 S-6	0.75	915	2.1	70.0	0.74	7.8	1.8	3.7	2.1	16	0.00323	32	
4KTC 90 L-6	1.1	915	3.0	73.0	0.73	11.5	2.1	4.1	2.3	16	0.00419	35	
4KTC 100 L-6	1.5	930	3.7	76.0	0.77	15.4	2.2	4.7	2.3	16	0.00657	46	
4KTC 112 M-6	2.2	960	5.0	82.0	0.78	21.9	2.6	6.1	2.7	16	0.0158	60	
4KTC 132 S-6	3.0	975	6.6	83.5	0.79	29.4	2.3	6.3	2.5	16	0.02722	84	
4KTC 132 MA-6	4.0	960	8.8	83.0	0.8	39.9	2.4	6.3	2.9	16	0.03229	88	
4KTC 132 MB-6	5.5	955	11.8	83.5	0.81	55.1	2.3	6.1	2.9	16	0.03838	95	
4KTC 160 M-6	7.5	970	15.8	86.0	0.8	74.2	2.7	6.7	2.4	16	0.08121	161	
4KTC 160 L-6	11.0	965	23.5	88.5	0.77	109.0	2.2	6.0	2.3	16	0.10916	182	
4KTC 180 L-6	15.0	965	31.0	89.5	0.78	148.0	1.9	5.2	2.3	16	0.227	236	
4KTC 200 LA-6	18.5	965	36.0	91.0	0.81	183.0	1.9	6.0	2.4	16	0.24369	240	
4KTC 200 LB-6	22.0	965	43.0	91.5	0.81	218.6	1.9	6.0	2.4	16	0.27888	250	
4KTC 225 M-6	30.0	975	56.0	92.5	0.83	293.0	1.8	5.8	2.5	16	0.66117	390	
4KTC 250 M-6	37.0	985	69.0	93.5	0.83	359.0	2.8	6.0	2.6	16	1.125	480	
4KTC 280 S-6	45.0	985	82.0	94.5	0.84	437.0	2.5	6.3	2.7	16	2.3	610	
4KTC 280 M-6	55.0	985	101.0	94.5	0.84	534.0	2.4	6.0	2.8	16	2.625	685	
4KTC 315 S-6	75.0	980	140.0	95.0	0.82	732.0	2.5	5.9	2.8	16	4.625	820	
4KTC 315 MA-6	90.0	985	163.0	95.5	0.84	874.0	2.1	5.1	2.9	16	5.25	930	
4KTC 315 MB-6	110.0	990	198.0	91.5	0.88	1060	2.5	6.5	2.4	16	6	1240	
4KTC 315 L-6	132.0	990	238.0	90.5	0.88	1275	2.6	6.8	2.4	16	7.3	1380	



Three-phase motor with short-circuit rotor

Pole number 8

220 - 240 V / 380 - 415 V 50 Hz
380 - 415 V / 660 - 690 V 50 Hz

Protection class IP 55
Temperature class T1 - T4
Thermal class F

Explosion protection			
Certificate	Type 4KTC or 4KTCD		Type 4KTC
	71	80 90 100 112 132 160	180 200 225
	250 280 315		
PTB 99 ATEX 1138	●	●	
PTB 99 ATEX 1005	● ● ● ● ● ●		
PTB 00 ATEX 1080			
PTB 05 ATEX 1054		●	
PTB 05 ATEX 1099		●	
PTB 05 ATEX 1100		●	
PTB 03 ATEX 1127			●
PTB 03 ATEX 1141			●
PTB 03 ATEX 1126			●

Selection chart

Type	Power kW	Speed min ⁻¹	In 440 V A	Efficiency %	Power factor cos φ	Torque Nm	Starting torque (MA/MN)	Starting current (IA/IN)	Max. torque (MM/MN)	KR	Moment of inertia (kgm ²)	Weight kg
4KTC 71 A-8	0.09	680	0.67	38.0	0.51	1.26	2.0	2.0	2.1	16	0.00081	15
4KTC 71 B-8	0.12	655	0.54	45.0	0.71	1.75	1.8	2.4	2.1	16	0.00101	16
4KTC 80 A-8	0.18	680	0.66	61.0	0.65	2.53	2.1	2.9	2.2	16	0.00191	25
4KTC 80 B-8	0.25	680	0.92	58.0	0.68	3.52	2.1	3.1	2.3	16	0.00239	26.5
4KTC 90 S-8	0.37	685	1.25	66.0	0.65	5.2	1.7	3.0	2.0	16	0.00323	32
4KTC 90 L-8	0.55	685	1.75	69.0	0.66	7.7	1.75	3.1	2.1	16	0.00419	35
4KTC 100 LA-8	0.75	690	2.3	69.0	0.69	10.4	1.8	3.5	2.1	16	0.00657	42.5
4KTC 100 LB-8	1.1	695	3.25	70.0	0.7	15.0	1.9	3.8	2.2	16	0.00857	46
4KTC 112 M-8	1.5	710	4.15	78.0	0.67	20.2	2.0	4.3	2.5	16	0.0158	60
4KTC 132 S-8	2.2	710	5.5	79.0	0.74	29.6	1.9	4.3	2.2	16	0.02606	79
4KTC 132 M-8	3.0	710	7.2	80.0	0.76	40.4	2.1	4.8	2.3	16	0.03446	85
4KTC 160 MA-8	4.0	720	10.0	82.6	0.71	53.1	1.8	4.8	2.3	16	0.0688	146
4KTC 160 MB-8	5.5	715	13.4	84.0	0.71	73.6	1.8	4.8	2.1	16	0.08939	160
4KTC 160 L-8	7.5	725	16.7	86.5	0.75	98.8	2.3	5.8	2.1	16	0.12027	182
4KTC 180 L-8	11.0	715	25.0	86.7	0.74	147.0	1.8	4.2	2.5	16	0.227	236
4KTC 200 L-8	15.0	720	29.0	91.0	0.82	196.0	2.1	4.5	2.5	16	0.37827	250
4KTC 225 S-8	18.5	710	37.0	91.0	0.79	249.0	2.1	4.6	2.6	16	0.57008	310
4KTC 225 M-8	22.0	715	45.0	91.5	0.77	294.0	2.1	4.6	2.6	16	0.67806	390
4KTC 250 M-8	30.0	730	59.0	92.8	0.79	398.0	1.7	5.4	2.4	16	1.175	480
4KTC 280 S-8	37.0	730	74.0	93.0	0.78	485.0	1.9	6.0	2.3	16	2.3	610
4KTC 280 M-8	45.0	735	90.0	93.5	0.78	586.0	1.9	6.4	2.7	16	2.625	685
4KTC 315 S-8	55.0	735	104.0	94.5	0.81	716.0	2.2	6.2	2.3	16	4.625	820
4KTC 315 MA-8	75.0	740	140.0	94.5	0.82	969.0	1.8	6.3	2.1	16	5.25	930
4KTC 315 MB-8	90.0	740	173.0	91.1	0.83	1160	2.5	6.7	2.5	16	6.0	1240
4KTC 315 L-8	110.0	740	213.0	90.0	0.83	1420	2.6	6.9	2.5	16	7.3	1380



Tables with ratings for single-speed motors - 60 Hz

Three-phase motor with short-circuit rotor

Pole number 2

440 - 480 V 60 Hz

Protection class IP 55
 Temperature class T1 - T4
 Thermal class F

Explosion protection	⚠ II 2G EEx d IIC T4, ⚠ II 2G EEx de IIC T4 ⚠ II 2D IP6X T 135° C												
Certificate	Type 4KTC or 4KTCD						Type 4KTC			Type 4KTC			
	71	80	90	100	112	132	160	180	200	225	250	280	315
PTB 99 ATEX 1138	●						●						
PTB 99 ATEX 1005		●	●	●	●	●							
PTB 00 ATEX 1080													
PTB 05 ATEX 1054								●					
PTB 05 ATEX 1099									●				
PTB 05 ATEX 1100										●			
PTB 03 ATEX 1127											●		
PTB 03 ATEX 1141												●	
PTB 03 ATEX 1126													●

Selection chart

Type	Power kW	Speed min ⁻¹	In 440 V A	Efficiency %	Power factor cos φ	Torque Nm	Starting torque (MA/MN)	Starting current (IA/IN)	Max. torque (MM/MN)	KR	Moment of inertia (kgm ²)	Weight kg
4KTC 71 A-2	0.45	3300	1.16	74	0.88	1.3	2.4	3.7	2.7	16	0.00034	15
4KTC 71 B-2	0.66	3350	1.38	76	0.84	1.88	2.4	4.8	2.6	16	0.00042	16
4KTC 80 A-2	0.9	3380	1.55	86	0.88	2.55	2.4	5.6	2.5	16	0.00063	24
4KTC 80 B-2	1.3	3385	2.37	80.7	0.89	3.67	2.6	5.1	2.5	16	0.00079	26
4KTC 90 S-2	1.8	3435	3.45	76	0.85	5	2.1	5.7	2.4	16	0.00124	32
4KTC 90 L-2	2.6	3435	4.65	84	0.87	7.2	2.9	5.2	2.3	16	0.00155	34
4KTC 100 L-2	3.6	3390	6.5	85	0.86	10.2	2	6.2	2.4	16	0.00251	42.5
4KTC 112 M-2	4.8	3455	8.6	85	0.89	13.3	2.1	6.5	2.5	16	0.00451	58
4KTC 132 SA-2	6.6	3460	11.8	87	0.90	18.2	2.2	5.8	2.3	16	0.00969	77
4KTC 132 SB-2	9.0	3510	15.1	87	0.90	24.5	2.7	6.9	2.9	16	0.01225	84
4KTC 160 MA-2	13.0	3525	22.2	86	0.89	35.2	3	6.7	2.9	16	0.02943	148
4KTC 160 MB-2	18.0	3490	32.5	79	0.92	49.2	2.9	6.3	2.5	16	0.03912	166
4KTC 160 L-2	21.0	3520	32.5	93	0.92	57	2.7	6.8	2.8	16	0.0459	178
4KTC 180 M-2	24.0	3520	41.4	84	0.91	65	2.3	6.3	2.6	16	0.06151	205
4KTC 200 LA-2	34.0	3550	59	86	0.85	91.5	1.9	6.4	2.3	16	0.10442	240
4KTC 200 LB-2	42.0	3550	70	87	0.90	113	2.7	8	2.7	16	0.12739	250
4KTC 225 M-2	52.0	3520	88	86	0.90	141	2	6.5	2.7	16	0.22155	375
4KTC 250 M-2	64.0	3560	104.5	93	0.89	172	1.8	6.1	2.1	16	0.675	485
4KTC 280 S-2	82.0	3570	133	90	0.90	219	2.5	7.7	2.1	16	0.96	650
4KTC 280 M-2	100.0	3570	162	90	0.90	270	2.4	7.3	2	16	1.1	700
4KTC 315 S-2	120.0	3570	183	92	0.94	321	2.1	6.7	2.6	13	1.55	820
4KTC 315 MA-2	132.0	3580	219	89	0.89	357	1.5	5.6	1.6	13	1.8	930
4KTC 315 MB-2	160.0	3570	251	89	0.94	428	2.4	8	2.6	13	2.25	1240
4KTC 315 L-2	200.0	3575	320	91	0.90	535	2.1	7.4	2.3	13	2.8	1380



Three-phase motor with short-circuit rotor

Pole number 4

440 - 480 V 60 Hz

Protection class IP 55
 Temperature class T1 - T4
 Thermal class F

Explosion protection				
Certificate	Type 4KTC or 4KTCD		Type 4KTC	
	71	80 90 100 112 132 160	180 200 225	
	250 280 315			
PTB 99 ATEX 1138	●	●		
PTB 99 ATEX 1005	● ● ● ● ● ●			
PTB 00 ATEX 1080				
PTB 05 ATEX 1054		●		
PTB 05 ATEX 1099			●	
PTB 05 ATEX 1100			●	
PTB 03 ATEX 1127				●
PTB 03 ATEX 1141				●
PTB 03 ATEX 1126				●

Selection chart

Type	Power kW	Speed min ⁻¹	In 440 V A	Efficiency %	Power factor cos φ	Torque Nm	Starting torque (MA/MN)	Starting current (IA/IN)	Max. torque (MM/MN)	KR	Moment of inertia (kgm ²)	Weight kg
4KTC 71 A-4	0.30	1640	0.80	60	0.78	1.75	1.8	3	1.9	16	0.00051	15
4KTC 71 B-4	0.45	1650	1.01	71	0.82	2.60	2.1	4.1	2	16	0.00063	16
4KTC 80 A-4	0.66	1640	1.52	75	0.83	3.84	1.9	4.1	2	16	0.00098	24
4 KTC 80 B-4	0.90	1670	1.87	75	0.82	5.10	2.2	4.2	2.3	16	0.00125	26
4KTC 90 S-4	1.3	1675	2.47	82	0.85	7.40	1.9	5.2	2.1	16	0.00204	32
4KTC 90 L-4	1.8	1680	3.40	82	0.85	10.2	2.3	5.8	2.3	16	0.0026	35
4KTC 100 LA-4	2.6	1675	5.1	74	0.85	14.8	1.7	4.2	1.7	16	0.00388	42.5
4KTC 100 LB-4	3.6	1680	6.8	80	0.86	20.5	1.8	4.7	2.2	16	0.00499	46
4KTC 112 M-4	4.8	1730	8.6	87	0.85	26.5	2.3	6.1	2.8	16	0.01014	60
4KTC 132 S-4	6.6	1700	12.3	87	0.87	37	1.9	4.8	1.9	16	0.02113	84
4KTC 132 M-4	9.0	1730	15.6	88	0.86	49.6	2.3	4.6	2.3	16	0.02793	93.5
4KTC 160 M-4	13.0	1730	23.4	88	0.86	71.8	2.3	5	2.4	16	0.05417	159
4KTC 160 L-4	17.5	1755	29.3	88	0.86	94.2	2.3	6.3	2.5	16	0.07116	178
4KTC 180 M-4	21	1740	36.3	88	0.87	115	2.8	5.8	2.2	16	0.1129	215
4KTC 180 L-4	26	1770	42.7	91	0.85	140	2.7	6.5	2.2	16	0.1339	236
4KTC 200 L-4	34	1760	54	92	0.92	185	2.4	6	2.5	16	0.21298	250
4KTC 225 S-4	44	1770	71.8	91	0.88	237	2.1	5.8	1.9	16	0.36225	310
4KTC 225 M-4	52	1775	84.4	93	0.87	280	2.4	5.9	2.2	16	0.42845	390
4KTC 250 M-4	64	1770	104	90	0.9	345	3	7.6	2.2	16	0.875	480
4KTC 280 S-4	87	1780	144	91	0.86	467	2.3	5.5	1.8	16	1.875	610
4KTC 280 M-4	90	1790	148	93	0.85	481	2.5	8.6	2.3	16	2.25	685
4KTC 315 S-4	110	1790	186	89	0.87	588	2.4	6.7	2.1	16	3.9	820
4KTC 315 MA-4	132	1790	214	92	0.89	714	2.7	6.4	2.3	16	3.875	930
4KTC 315 MB-4	170	1795	288	92	0.85	905	1.5	5.5	1.6	16	5	1240
4KTC 315 L-4	200	1785	324	93	0.87	1071	1.6	6.8	1.8	16	6.1	1380



Three-phase motor with short-circuit rotor

Pole number 6

440 - 480 V 60 Hz

Protection class IP 55
 Temperature class T1 - T4
 Thermal class F

Explosion protection	 			
Certificate	Type 4KTC or 4KTCD		Type 4KTC	Type 4KTC
	71	80 90 100 112 132 160	180 200 225	250 280 315
PTB 99 ATEX 1138	●	●		
PTB 99 ATEX 1005	●	●		
PTB 00 ATEX 1080				
PTB 05 ATEX 1054			●	
PTB 05 ATEX 1099			●	
PTB 05 ATEX 1100			●	
PTB 03 ATEX 1127				●
PTB 03 ATEX 1141				●
PTB 03 ATEX 1126				●

Selection chart													
Type	Power	Speed	In	Efficiency	Power	Torque	Starting	Starting	Max.	KR	Moment	Weight	
	kW	min ⁻¹	440 V A	%	factor cos φ	Nm	torque (MA/MN)	current (IA/IN)	torque (MM/MN)		of inertia (kgm ²)	kg	
4KTC 71 A-6	0.18	1115	0.67	60	0.65	1.55	2.1	3.1	2.3	16	0.00081	15	
4KTC 71 B-6	0.25	1100	0.76	62	0.7	2.18	2.4	2.9	2.5	16	0.00101	16	
4KTC 80 A-6	0.37	1100	1.06	62	0.74	3.23	2.1	3.5	2.5	16	0.00191	25	
4KTC 80 B-6	0.55	1100	1.36	71	0.74	4.8	2.4	4.2	2.4	16	0.00239	26.5	
4KTC 90 S-6	0.75	1090	1.94	69	0.72	6.6	1.8	3.6	2	16	0.0323	32	
4KTC 90 L-6	1.1	1105	2.73	76	0.71	9.5	1.8	3.9	2.1	16	0.00419	35	
4KTC 100 L-6	1.5	1110	3.35	76	0.76	12.8	2.2	4.8	2.2	16	0.00657	46	
4KTC 112 M-6	2.2	1180	4.5	84	0.71	18	2.6	6.3	2.7	16	0.0158	60	
4KTC 132 S-6	3.0	1170	6	82	0.79	24	2.3	6.4	2.5	16	0.02722	84	
4KTC 132 MA-6	4.0	1150	8.1	80	0.8	33	2.4	6.2	2.9	16	0.03229	88	
4KTC 132 MB-6	5.5	1150	10.8	81	0.82	45	2.3	6.2	3	16	0.03838	95	
4KTC 160 M-6	7.5	1170	14.4	84	0.81	61	2.8	6.7	2.4	16	0.08121	161	
4KTC 160 L-6	11.0	1165	20	86	0.83	90	2.3	7.2	3.6	16	0.10916	182	
4KTC 180 L-6	15.0	1175	27.6	89	0.8	121	2.5	7.6	3.7	16	0.227	236	
4KTC 200 LA-6	18.5	1175	32.6	89	0.83	150	1.4	5.6	2.3	13	0.24369	240	
4KTC 200 LB-6	22.0	1180	39.3	91	0.81	178	2.2	8	3.3	16	0.27888	250	
4KTC 225 M-6	30.0	1180	53.5	91	0.81	244	2.4	6.5	1.9	16	0.66117	390	
4KTC 250 M-6	37.0	1185	69	92	0.75	298	1.9	4.1	1.7	13	1.125	480	
4KTC 280 S-6	52.0	1185	94	91	0.8	418	1.9	4.4	1.9	16	2.3	610	
4KTC 280 M-6	66.0	1170	119	90	0.82	540	1.7	3.7	1.6	16	2.625	685	
4KTC 315 S-6	75.0	1180	140	95	0.82	610	2.5	5.9	2.8	16	4.625	820	
4KTC 315 MA-6	90.0	1180	163	95	0.84	728	2.1	5.1	2.9	16	5.25	930	
4KTC 315 MB-6	110.0	1190	175	94	0.88	884	2.1	6.1	2.2	16	6	1240	
4KTC 315 L-6	132.0	1190	210	94	0.88	1160	2.0	6.3	2.1	16	7.3	1380	



Three-phase motor with short-circuit rotor

Pole number 8

440 - 480 V 60 Hz

Protection class IP 55
 Temperature class T1 - T4
 Thermal class F

Explosion protection				
Certificate	Type 4KTC or 4KTCD		Type 4KTC	Type 4KTC
	71	80 90 100 112 132 160	180 200 225	250 280 315
PTB 99 ATEX 1138	●	●		
PTB 99 ATEX 1005	●	●		
PTB 00 ATEX 1080		●		
PTB 05 ATEX 1054			●	
PTB 05 ATEX 1099			●	
PTB 05 ATEX 1100			●	
PTB 03 ATEX 1127				●
PTB 03 ATEX 1141				●
PTB 03 ATEX 1126				●

Selection chart

Type	Power kW	Speed min ⁻¹	In 440 V A	Efficiency %	Power factor cos φ	Torque Nm	Starting torque (MA/MN)	Starting current (IA/IN)	Max. torque (MM/MN)	KR	Moment of inertia (kgm ²)	Weight kg
4KTC 71 A-8	0.09	820	0.42	45	0.62	1	2.2	2.5	2.1	16	0.00081	15
4KTC 71 B-8	0.12	780	0.49	45	0.71	1.47	1.8	2.4	2	16	0.00101	16
4KTC 80 A-8	0.18	825	0.62	58	0.63	2.1	2.1	2.9	2.1	16	0.00191	25
4KTC 80 B-8	0.25	825	0.84	58	0.67	2.9	2	3.1	2.3	16	0.00239	26.5
4KTC 90 S-8	0.37	820	1.17	64	0.62	4.3	1.6	2.9	1.9	16	0.00323	32
4KTC 90 L-8	0.55	825	1.6	72	0.61	6.4	1.7	3.2	2	16	0.00419	35
4KTC 100 LA-8	0.75	825	2.14	67	0.66	8.7	1.6	3.5	1.9	16	0.00657	42.5
4KTC 100 LB-8	1.1	845	3.1	71	0.62	12.4	2	4	2.3	16	0.00857	46
4KTC 112 M-8	1.5	855	3.8	77	0.67	16.8	2	4.3	2.5	16	0.0158	60
4KTC 132 S-8	2.2	845	5	75	0.76	24.6	1.8	4.3	2.2	16	0.02606	79
4KTC 132 M-8	3.0	850	6.6	79	0.73	33	2.2	4.9	2.3	16	0.03446	85
4KTC 160 MA-8	4.0	865	8.5	81	0.76	44	1.9	5.3	2.3	16	0.0688	146
4KTC 160 MB-8	5.5	865	10.9	84	0.78	60	1.9	5	2.1	16	0.08939	160
4KTC 160 L-8	7.5	875	15.3	85	0.76	82	2.3	6.2	2.1	16	0.12027	182
4KTC 180 L-8	11.0	870	20.7	88	0.8	121	2	5.8	2.5	16	0.227	236
4KTC 200 L-8	15.0	880	27.7	91	0.78	163	2.4	7.4	3.7	16	0.37827	250
4KTC 225 S-8	18.5	885	35	91	0.76	200	2.4	7.6	3.2	16	0.57008	310
4KTC 225 M-8	22.0	885	42	90	0.77	239	2.2	6.9	3.1	16	0.67806	390
4KTC 250 M-8	30.0	875	59	92	0.79	332	1.7	5.4	2.4	16	1.175	480
4KTC 280 S-8	37.0	875	74	93	0.78	404	1.9	6	2.3	16	2.3	610
4KTC 280 M-8	45.0	880	90	93	0.78	488	1.9	6.4	2.7	16	2.625	689
4KTC 315 S-8	55.0	880	104	94	0.81	597	2.2	6.2	2.3	16	4.625	820
4KTC 315 MA-8	75.0	890	140	94	0.82	969	1.8	6.3	2.1	16	5.25	930
4KTC 315 MB-8	90.0	885	153	93	0.83	973	1.9	6.4	2.0	16	6.0	1240
4KTC 315 L-8	110.0	885	189	93	0.82	1189	1.8	6.3	1.9	16	7.3	1380



*Technical data and tables with ratings
for pole changing motors - constant torque*

Three-phase motor with short-circuit rotor

Pole number 4/2

D/YY 380 - 415 V 50 Hz

Protection class IP 55
Temperature class T1 - T4
Thermal class F

Explosion protection	 												
	Type 4KTC or 4KTCD						Type 4KTC			Type 4KTC			
	71	80	90	100	112	132	160	180	200	225	250	280	315
PTB 99 ATEX 1138	●						●						
PTB 99 ATEX 1005		●	●	●	●	●							
PTB 00 ATEX 1080													
PTB 05 ATEX 1054								●					
PTB 05 ATEX 1099									●				
PTB 05 ATEX 1100										●			
PTB 03 ATEX 1127											●		
PTB 03 ATEX 1141												●	
PTB 03 ATEX 1126													●

Selection chart

Type	Power kW	Speed min ⁻¹	In 400 V A	Starting current (IA/IN)	Max. torque (MM/MN)	Weight kg	Type	Power kW	Speed min ⁻¹	In 400 V A	Starting current (IA/IN)	Max. torque (MM/MN)	Weight kg
4KTC 71 A-4/2	0.21	1380	0.75	3.6	2.1	16	4KTC 160 L-4/2	12	1470	27.5	7.2	2.8	189
	0.28	2800	0.9	3.9	2.1			15	2940	31	7.5	2.7	
4KTC 71 B-4/2	0.3	1380	1.05	3.8	2.1	17	4KTC 180 M-4/2	14	1470	29	6.8	2.5	220
	0.43	2800	1.25	4.0	2.0			17	2940	33	7.5	2.5	
4KTC 80 A-4/2	0.5	1370	1.26	3.7	1.8	25	4KTC 180 L-4/2	17	1475	35	6.9	2.5	240
	0.65	2760	1.43	3.4	1.9			20	2950	39	7.5	2.5	
4KTC 80 B-4/2	0.7	1365	1.75	4.1	2.0	28	4KTC 200 L-4/2	20	1475	41	7.0	2.5	260
	0.85	2810	1.85	5.5	2.4			23	2950	46	7.5	2.5	
4KTC 90 S-4/2	1.1	1415	2.6	4.4	1.9	34	4KTC 225 S-4/2	24	1480	46	7.0	2.5	320
	1.4	2800	2.95	4.7	2.0			28	2955	59	7.5	2.5	
4KTC 90 L-4/2	1.5	1410	3.3	4.9	2.1	36	4KTC 225 M-4/2	29	1485	62	7.2	2.5	400
	1.9	2850	3.9	5.3	2.3			34	2960	66	7.6	2.6	
4KTC 100 LA-4/2	1.8	1430	4.16	4.8	2.0	45	4KTC 250 M-4/2	36	1485	77	7.1	2.4	490
	2.4	2860	5.25	5.0	1.9			45	1960	87	7.5	2.5	
4KTC 100 LB-4/2	2.6	1420	5.65	5.85	2.1	49	4KTC 280 S-4/2	46	1480	85	6.8	2.0	610
	3.2	2870	6.6	6.6	2.3			58	2970	95	7.0	2.0	
4KTC 112 M-4/2	3.7	1460	8.4	6.6	2.8	64	4KTC 280 M-4/2	65	1480	128	6.6	1.8	685
	4.4	2890	8.5	7.4	2.9			80	2970	142	6.8	1.8	
4KTC 132 S-4/2	5.0	1460	11.5	6.2	2.7	89	4KTC 315 S-4/2	78	1485	154	6.5	1.8	820
	6.0	2900	11.9	6.4	2.8			90	2970	176	6.0	1.7	
4KTC 132 M-4/2	6.1	1450	13.8	6.7	2.5	99	4KTC 315MA-4/2	90	1485	156	6.5	1.8	930
	7.5	2910	15.4	6.9	2.3			100	2970	190	6.2	1.7	
4KTC 160 M-4/2	9.0	1465	19.5	6.5	2.3	169	4KTC 315MB-4/2	100	1485	208	6.2	1.8	1240
	10.5	2930	22	7.5	2.2			120	2970	230	6.0	1.6	



Three-phase motor with short-circuit rotor

Pole number 8/4

D/YY 380 - 415 V 50 Hz

Protection class IP 55
 Temperature class T1 - T4
 Thermal class F

Explosion protection	II 2G EEx d IIC T4, II 2G EEx de IIC T4 II 2D IP6X T 135° C												
Certificate	Type 4KTC or 4KTCD						Type 4KTC			Type 4KTC			
	71	80	90	100	112	132	160	180	200	225	250	280	315
PTB 99 ATEX 1138	●						●						
PTB 99 ATEX 1005		●	●	●	●	●							
PTB 00 ATEX 1080													
PTB 05 ATEX 1054								●					
PTB 05 ATEX 1099									●				
PTB 05 ATEX 1100										●			
PTB 03 ATEX 1127											●		
PTB 03 ATEX 1141												●	
PTB 03 ATEX 1126													●

Selection chart

Type	Power kW	Speed min ⁻¹	In 400 V A	Starting current (IA/IN)	Max. torque (MM/MN)	Weight kg	Type	Power kW	Speed min ⁻¹	In 400 V A	Starting current (IA/IN)	Max. torque (MM/MN)	Weight kg
4KTC 71 A-8/4	0.048	620	0.32	2.1	1.6	16	4KTC 160MB-8/4	4.6	725	12.8	4.6	1.8	165
	0.22	1370	0.57	3.8	1.8			7.3	1460	14.6	7.0	1.9	
4KTC 71 B-8/4	0.07	620	0.47	2.1	1.6	17	4KTC 160 L-8/4	6.8	725	21	4.8	1.8	197
	0.32	1370	0.82	3.8	1.8			11	1460	23	7.0	2.0	
4KTC 80 A-8/4	0.2	690	0.83	2.8	2.0	25	4KTC 180 L-8/4	11	725	29	4.6	1.7	240
	0.3	1380	0.79	3.9	2.2			15	1460	30	7.0	2.0	
4KTC 80 B-8/4	0.27	690	1.08	2.9	2.1	28	4KTC 200 L-8/4	15	730	33	5.3	1.5	260
	0.4	1400	0.96	4.5	2.2			20	1465	44	6.8	1.8	
4KTC 90 S-8/4	0.42	705	1.9	2.8	2.0	34	4KTC 225 S-8/4	18	730	42	5.3	1.6	320
	0.8	1390	1.9	3.9	1.8			24	1465	50	6.8	1.8	
4KTC 90 L-8/4	0.5	710	2.3	3.1	2.1	36	4KTC 225 M-8/4	22	730	50	5.0	1.5	400
	1.0	1410	2.25	4.3	1.9			28	1465	55	7.0	2.0	
4KTC 100 LA-8/4	0.9	690	3.05	3.2	2.1	45	4KTC 250 M-8/4	30	730	67	4.5	1.5	490
	1.3	1380	3.0	4.2	2.1			42	1465	80	6.5	2.0	
4KTC 100 LB-8/4	1.0	720	3.2	3.9	2.1	49	4KTC 280 S-8/4	35	735	80	4.6	1.6	610
	1.6	1430	3.35	5.3	2.2			51	1470	96	6.5	1.6	
4KTC 112 M-8/4	1.5	710	4.25	4.6	2.2	64	4KTC 280 M-8/4	42	735	88	5.0	1.5	685
	2.5	1430	5.0	5.7	2.1			60	1470	105	6.3	1.5	
4KTC 132 S-8/4	2.3	720	6.7	5.3	2.3	89	4KTC 315 S-8/4	52	740	109	5.0	1.6	820
	3.6	1450	7.3	6.9	2.2			68	1475	130	6.4	1.5	
4KTC 132 M-8/4	3.0	720	9.5	4.5	2.3	99	4KTC 315 M-8/4	70	740	147	5.8	1.7	930
	5.0	1445	9.9	5.4	2.3			90	1475	173	6.5	1.5	
4KTC 160 MA-8/4	4.0	725	10.5	5.2	1.8	155							
	5.5	1460	10.8	7.0	1.8								



Three-phase motor with short-circuit rotor

Pole number 6/4

Y/Y 380 - 415 V 50 Hz

Protection class IP 55
 Temperature class T1 - T4
 Thermal class F

Explosion protection	 												
Certificate	Type 4KTC or 4KTCD						Type 4KTC			Type 4KTC			
	71	80	90	100	112	132	160	180	200	225	250	280	315
PTB 99 ATEX 1138	●						●						
PTB 99 ATEX 1005		●	●	●	●	●							
PTB 00 ATEX 1080													
PTB 05 ATEX 1054								●					
PTB 05 ATEX 1099									●				
PTB 05 ATEX 1100										●			
PTB 03 ATEX 1127											●		
PTB 03 ATEX 1141												●	
PTB 03 ATEX 1126													●

Selection chart															
Type	Power kW	Speed min ⁻¹	In 400 V A	Starting current (IA/IN)	Max. torque (MM/MN)	Weight kg		Type	Power kW	Speed min ⁻¹	In 400 V A	Starting current (IA/IN)	Max. torque (MM/MN)	Weight kg	
4KTC 71 A-6/4	0.15 0.2	920 1440	0.75 0.85	2.6 3.3	1.5 1.5	16		4KTC 160 L-6/4	5.5 8	980 1480	13.3 16.8	7.0 7.0	2.1 2.0	197	
4KTC 71 B-6/4	0.21 0.3	920 1420	1.20 1.35	2.6 3.4	2.0 1.9	17		4KTC 180 M-6/4	7.5 11	980 1470	16.6 22	6.3 6.5	2.0 1.6	220	
4KTC 80 A-6/4	0.22 0.32	930 1455	0.7 1.05	3.3 4.2	1.9 2.1	25		4KTC 180 L-6/4	9 13	980 1470	20 26	6.5 7.0	2.0 1.5	240	
4KTC 80 B-6/4	0.26 0.4	940 1425	0.94 1.28	3.5 3.6	2.2 1.9	28		4KTC 200 L-6/4	13 19	980 1470	31 39	6.8 7.2	2.1 2.2	260	
4KTC 90 S-6/4	0.45 0.66	945 1450	1.5 1.75	3.6 5.3	2.1 2.2	34		4KTC 225 S-6/4	19 23	980 1470	40 48	6.0 6.3	2.0 2.2	320	
4KTC 90 L-6/4	0.6 0.9	960 1425	1.8 2.1	3.6 4.4	2.1 1.9	36		4KTC 225 M-6/4	23 27	980 1470	48 56	6.0 6.5	2.1 2.0	400	
4KTC 100 LA-6/4	0.9 1.3	960 1420	2.4 3.0	4.0 4.5	1.8 1.9	45		4KTC 250 M-6/4	27 32	980 1470	53 65	6.0 6.5	2.1 2.2	490	
4KTC 100 LB-6/4	1.1 1.7	960 1450	2.8 3.7	4.3 4.7	1.8 2.1	49		4KTC 280 S-6/4	32 45	985 1475	63 89	6.5 7.0	2.3 2.7	610	
4KTC 112 M-6/4	1.5 2.4	970 1450	3.55 5.05	5.3 5.4	2.2 1.9	64		4KTC 280 M-6/4	37 55	985 1475	72 108	6.5 7.0	2.3 2.7	685	
4KTC 132 S-6/4	2.2 3.0	965 1465	5.05 6.0	5.7 6.1	1.9 2.1	89		4KTC 315 S-6/4	45 67	985 1485	88 130	6.8 7.2	2.1 2.3	820	
4KTC 132 M-6/4	3.0 4.5	975 1460	6.7 8.9	6.5 6.3	2.2 1.9	99		4KTC 315 M-6/4	55 80	985 1485	108 155	6.8 7.2	2.1 2.3	930	



Three-phase motor with short-circuit rotor

Pole number 8/6

Y/Y 380 - 415 V 50 Hz

Protection class IP 55
 Temperature class T1 - T4
 Thermal class F

Explosion protection	⚠ II 2G EEx d IIC T4, ⚠ II 2G EEx de IIC T4 ⚠ II 2D IP6X T 135° C												
Certificate	Type 4KTC or 4KTCD						Type 4KTC			Type 4KTC			
	71	80	90	100	112	132	160	180	200	225	250	280	315
PTB 99 ATEX 1138	●						●						
PTB 99 ATEX 1005		●	●	●	●	●							
PTB 00 ATEX 1080													
PTB 05 ATEX 1054								●					
PTB 05 ATEX 1099									●				
PTB 05 ATEX 1100										●			
PTB 03 ATEX 1127											●		
PTB 03 ATEX 1141												●	
PTB 03 ATEX 1126													●

Selection chart

Type	Power kW	Speed min ⁻¹	In 400 V A	Starting current (IA/IN)	Max. torque (MM/MN)	Weight kg
4KTC 90 S-8/6	0.35	695	1.35	2.7	1.7	34
	0.45	960	1.5	3.3	1.8	
4KTC 90 L-8/6	0.45	695	1.68	2.7	1.8	36
	0.6	960	2.07	3.5	2.0	
4KTC 100 LA-8/6	0.6	715	2.05	2.9	1.6	45
	0.8	970	2.15	4.1	1.8	
4KTC 100 LB-8/6	0.75	710	2.4	3.1	1.6	49
	0.9	970	2.5	4.7	2.0	
4KTC 112 M-8/6	0.9	720	2.8	4.2	2.2	64
	1.2	970	3.0	5.1	2.4	
4KTC 132 S-8/6	1.5	725	5.05	4.8	2.5	89
	2.0	975	5.5	6.2	2.4	
4KTC 132 M-8/6	2.2	725	6.8	3.9	2.1	99
	3.0	975	8.1	5.3	2.2	
4KTC 160 M-8/6	3.5	725	8.8	5.5	2.3	155
	5.0	975	12.0	6.4	2.1	
4KTC 160 L-8/6	5.0	725	12.0	5.5	2.4	197
	7.0	975	16.0	6.5	2.2	

Type	Power kW	Speed min ⁻¹	In 400 V A	Starting current (IA/IN)	Max. torque (MM/MN)	Weight kg
4KTC 180 L-8/6	7.0	725	18	5.5	2.0	240
	9.5	980	24	6.2	1.8	
4KTC 200 L-8/6	10	725	23	5.5	2.3	260
	13	980	27	6.8	2.1	
4KTC 225 S-8/6	13	725	29	5.3	1.7	320
	16	975	36	6.2	1.4	
4KTC 225 M-8/6	17	725	42	5.4	1.7	400
	22	975	54	6.5	1.4	
4KTC 250 M-8/6	22	730	51	5.8	1.9	490
	30	985	65	6.5	1.6	
4KTC 280 S-8/6	27	735	63	5.8	1.8	610
	35	985	80	6.5	1.5	
4KTC 280 M-8/6	33	735	74	6.0	1.8	685
	41	985	90	6.7	1.5	
4KTC 315 S-8/6	40	735	90	6.0	1.8	820
	50	985	102	7.0	1.4	
4KTC 315 M-8/6	48	735	103	6.0	1.8	930
	62	985	125	7.0	1.4	



Three-phase motor with short-circuit rotor

Pole number 4/2

D/YY 440 - 480 V 60 Hz

Protection class IP 55
 Temperature class T1 - T4
 Thermal class F

Explosion protection	 												
Certificate	Type 4KTC or 4KTCD						Type 4KTC			Type 4KTC			
	71	80	90	100	112	132	160	180	200	225	250	280	315
PTB 99 ATEX 1138	●						●						
PTB 99 ATEX 1005		●	●	●	●	●							
PTB 00 ATEX 1080													
PTB 05 ATEX 1054								●					
PTB 05 ATEX 1099									●				
PTB 05 ATEX 1100										●			
PTB 03 ATEX 1127											●		
PTB 03 ATEX 1141												●	
PTB 03 ATEX 1126													●

Selection chart

Type	Power kW	Speed min ⁻¹	In (A) 440 Volt	Starting current (IA/IN)	Max. torque (MM/MN)	Weight kg	Type	Power kW	Speed min ⁻¹	In (A) 440 Volt	Starting current (IA/IN)	Max. torque (MM/MN)	Weight kg
4KTC 71 A-4/2	0.23 0.3	1660 3360	0.75 0.9	3.4 3.7	1.8 1.8	16	4KTC 160 L-4/2	13 16	1760 3540	27.5 32.0	8.5 7.6	3.0 2.6	189
4KTC 71 B-4/2	0.33 0.45	1600 3360	1.05 1.25	3.6 3.8	1.8 1.7	17	4KTC 180 M-4/2	15 18	1760 3530	29 33	6.5 7.1	2.1 2.1	220
4KTC 80 A-4/2	0.55 0.7	1640 3310	1.26 1.43	3.5 3.2	1.5 1.6	25	4KTC 180 L-4/2	18 22	1770 3540	35 39	6.5 7.1	2.1 2.1	240
4KTC 80 B-4/2	0.75 0.9	1640 3380	1.75 1.85	3.9 5.2	1.6 1.9	28	4KTC 200 L-4/2	22 25	1780 3550	37 43	8.0 8.0	2.6 2.1	260
4KTC 90 S-4/2	1.2 1.5	1700 3360	2.6 3	4.2 4.4	1.4 1.5	34	4KTC 225 S-4/2	26 30	1780 3550	46 59	6.6 7.1	2.1 2.1	320
4KTC 90 L-4/2	1.6 2	1690 3420	3.3 3.9	4.6 5	1.6 1.8	36	4KTC 225 M-4/2	31 37	1780 3550	62 66	6.8 7.2	2.1 2.2	400
4KTC 100 LA-4/2	2.0 2.6	1710 3410	4.1 5.2	4.5 3.9	1.5 1.5	45	4KTC 250 M-4/2	40 50	1780 3550	77 87	6.7 7.1	2.0 2.1	490
4KTC 100 LB-4/2	2.8 3.5	1700 3440	5.65 6.6	4.8 5.5	1.6 1.7	49	4KTC 280 S-4/2	50 63	1780 3560	85 95	6.5 6.6	1.7 1.7	610
4KTC 112 M-4/2	4.0 4.8	1750 3470	8.4 8.5	6.3 7.0	2.0 2.0	64	4KTC 280 M-4/2	71 88	1780 3560	128 142	6.3 6.5	1.5 1.5	685
4KTC 132 S-4/2	5.5 6.5	1750 3480	11.5 11.9	5.9 6.0	2.3 2.4	89	4KTC 315 S-4/2	85 98	1780 3560	154 176	6.2 5.7	1.5 1.5	820
4KTC 132 M-4/2	6.5 8.0	1750 3490	13.5 14.5	5.5 6.0	1.9 1.9	99	4KTC 315MA-4/2	98 110	1780 3560	156 190	6.2 5.9	1.5 1.5	930
4KTC 160 M-4/2	10.0 11.0	1760 3520	19.5 22.0	6.2 7.1	2.0 2.2	1.9	4KTC 315MB-4/2	110 130	1780 3560	208 230	5.9 5.7	1.5 1.4	1240



Three-phase motor with short-circuit rotor

Pole number 8/4

D/YY 440 - 480 V 60 Hz

Protection class IP 55
 Temperature class T1 - T4
 Thermal class F

Explosion protection	⚠ II 2G EEx d IIC T4, ⚠ II 2G EEx de IIC T4 ⚠ II 2D IP6X T 135° C												
Certificate	Type 4KTC or 4KTCD						Type 4KTC			Type 4KTC			
	71	80	90	100	112	132	160	180	200	225	250	280	315
PTB 99 ATEX 1138	●						●						
PTB 99 ATEX 1005		●	●	●	●	●							
PTB 00 ATEX 1080													
PTB 05 ATEX 1054								●					
PTB 05 ATEX 1099									●				
PTB 05 ATEX 1100										●			
PTB 03 ATEX 1127											●		
PTB 03 ATEX 1141												●	
PTB 03 ATEX 1126													●

Selection chart

Type	Power kW	Speed min ⁻¹	In 440 V A	Starting current (IA/IN)	Max. torque (MM/MN)	Weight kg	Type	Power kW	Speed min ⁻¹	In 440 V A	Starting current (IA/IN)	Max. torque (MM/MN)	Weight kg
4KTC 71 A-8/4	0.05 0.24	740 1640	0.32 0.57	2.0 3.6	1.4 1.5	16	4KTC 160MB-8/4	5 8	870 1740	11.7 14.3	5.5 6.6	1.8 1.7	165
4KTC 71 B-8/4	0.08 0.35	740 1640	0.47 0.82	2.0 3.6	1.4 1.5	17	4KTC 160 L-8/4	7.5 12	870 1750	16.5 20.2	5.7 6.8	1.8 1.5	220
4KTC 80 A-8/4	0.22 0.33	830 1660	0.83 0.79	2.7 3.7	1.5 1.7	25	4KTC 180 L-8/4	12 16	870 1750	29 30	4.4 6.6	1.5 1.7	240
4KTC 80 B-8/4	0.30 0.44	830 1680	1.08 0.96	2.7 4.3	1.7 1.7	28	4KTC 200 L-8/4	16 22	890 1780	33.8 42.4	7.3 8.9	2.1 2.2	260
4KTC 90 S-8/4	0.46 0.85	850 1670	1.9 1.9	2.7 3.7	1.6 1.3	34	4KTC 225 S-8/4	20 26	880 1760	42 50	5.0 6.5	1.4 1.5	320
4KTC 90 L-8/4	0.55 1.10	850 1690	2.3 2.25	2.9 4.1	1.7 1.3	36	4KTC 225 M-8/4	24 30	880 1760	50 55	4.7 6.6	1.3 1.7	400
4KTC 100 LA-8/4	1.0 1.4	840 1690	3.0 3.0	3.1 4.7	1.5 1.5	45	4KTC 250 M-8/4	33 46	880 1760	67 80	4.3 6.2	1.3 1.7	490
4KTC 100 LB-8/4	1.1 1.7	860 1720	3.2 3.35	3.7 5.0	1.7 1.5	49	4KTC 280 S-8/4	38 56	880 1760	80 96	4.4 6.2	1.4 1.4	610
4KTC 112 M-8/4	1.6 2.7	860 1730	4.55 5.0	4.5 5.7	1.7 1.6	64	4KTC 280 M-8/4	46 66	880 1760	88 105	4.7 6.0	1.3 1.3	685
4KTC 132 S-8/4	2.5 4.0	870 1740	7.1 7.3	4.5 6.3	1.8 1.8	89	4KTC 315 S-8/4	57 75	890 1770	109 130	4.7 6.1	1.4 1.3	820
4KTC 132 M-8/4	3.3 5.5	880 1750	9.3 8.9	4.9 7.3	2.3 2.0	99	4KTC 315 M-8/4	77 100	890 1770	147 173	5.5 6.2	1.5 1.3	930
4KTC 160MA-8/4	4.4 6.0	870 1740	10.0 11.0	5.0 6.7	1.6 1.7	155							



Three-phase motor with short-circuit rotor

Pole number 6/4

Y/Y 440 - 480 V 60 Hz

Protection class IP 55
 Temperature class T1 - T4
 Thermal class F

Explosion protection	II 2G EEx d IIC T4, II 2G EEx de IIC T4 II 2D IP6X T 135° C												
Certificate	Type 4KTC or 4KTCD						Type 4KTC			Type 4KTC			
	71	80	90	100	112	132	160	180	200	225	250	280	315
PTB 99 ATEX 1138	●						●						
PTB 99 ATEX 1005		●	●	●	●	●							
PTB 00 ATEX 1080													
PTB 05 ATEX 1054								●					
PTB 05 ATEX 1099									●				
PTB 05 ATEX 1100										●			
PTB 03 ATEX 1127												●	
PTB 03 ATEX 1141													●
PTB 03 ATEX 1126													●

Selection chart

Type	Power kW	Speed min ⁻¹	In (A) 440 Volt	Starting current (IA/IN)	Max. torque (MM/MN)	Weight kg	Type	Power kW	Speed min ⁻¹	In (A) 440 Volt	Starting current (IA/IN)	Max. torque (MM/MN)	Weight kg
4KTC 71 A-6/4	0.16	1100	0.75	2.5	1.4	16	4KTC 160 L-6/4	6.0	1180	12.3	6.7	1.7	197
	0.22	1730	0.85	3.1	1.3			8.8	1770	15.5	8.5	2.0	
4KTC 71 B-6/4	0.23	1100	1.05	3.6	1.6	17	4KTC 180 M-6/4	8.2	1180	16.6	6.0	1.7	220
	0.33	1700	1.05	3.0	1.4			12	1760	22	6.2	1.4	
4KTC 80 A-6/4	0.24	1120	0.7	3.1	1.5	25	4KTC 180 L-6/4	10	1180	20	6.2	1.7	240
	0.35	1750	1.07	4.0	1.6			14	1760	26	6.6	1.3	
4KTC 80 B-6/4	0.28	1140	0.95	3.8	2.1	28	4KTC 200 L-6/4	14	1180	31	6.5	1.8	260
	0.44	1730	1.2	3.9	1.5			20	1760	39	6.8	1.9	
4KTC 90 S-6/4	0.5	1130	1.5	3.4	1.8	34	4KTC 225 S-6/4	20	1180	40	5.7	1.7	320
	0.7	1740	1.75	5.0	1.9			25	1760	48	6.0	1.9	
4KTC 90 L-6/4	0.65	1150	1.8	3.4	1.5	36	4KTC 225 M-6/4	25	1180	48	5.7	1.8	400
	1.0	1700	2.1	4.2	1.4			29	1760	56	6.2	1.7	
4KTC 100 LA-6/4	1.0	1150	2.4	3.8	1.3	45	4KTC 250 M-6/4	29	1180	53	5.7	1.8	490
	1.4	1700	3.0	4.3	1.4			35	1760	65	6.2	1.9	
4KTC 100 LB-6/4	1.2	1150	2.8	4.1	1.3	49	4KTC 280 S-6/4	35	1180	63	6.2	2.0	610
	1.8	1730	3.75	4.6	1.5			50	1770	89	6.6	2.3	
4KTC 112 M-6/4	1.6	1160	3.55	5.0	1.6	64	4KTC 280 M-6/4	40	1180	72	6.2	2.0	685
	2.6	1740	5.05	5.2	1.5			60	1770	108	6.6	2.3	
4KTC 132 S-6/4	2.4	1160	5.05	5.4	1.5	89	4KTC 315 S-6/4	50	1180	88	6.5	1.8	820
	3.3	1760	6.0	5.8	1.7			73	1780	130	6.8	2.0	
4KTC 132 M-6/4	3.3	1170	6.7	6.2	1.7	99	4KTC 315 M-6/4	60	1180	108	6.5	1.8	930
	5.0	1750	8.9	6.0	1.5			88	1780	155	6.8	2.0	
4KTC 160 M-6/4	4.0	1180	8.75	6.3	1.7	155							
	6.2	1760	11.8	7.6	1.7								



Three-phase motor with short-circuit rotor

Pole number 8/6

Y/Y 440 - 480 V 60 Hz

Protection class IP 55
 Temperature class T1 - T4
 Thermal class F

Explosion protection													
Certificate	Type 4KTC or 4KTCD						Type 4KTC			Type 4KTC			
	71	80	90	100	112	132	160	180	200	225	250	280	315
PTB 99 ATEX 1138	●						●						
PTB 99 ATEX 1005		●	●	●	●	●							
PTB 00 ATEX 1080													
PTB 05 ATEX 1054								●					
PTB 05 ATEX 1099									●				
PTB 05 ATEX 1100										●			
PTB 03 ATEX 1127											●		
PTB 03 ATEX 1141												●	
PTB 03 ATEX 1126													●

Selection chart

Type	Power kW	Speed min ⁻¹	In 440 V A	Starting current (IA/IN)	Max. torque (MM/MN)	Weight kg	Type	Power kW	Speed min ⁻¹	In 440 V A	Starting current (IA/IN)	Max. torque (MM/MN)	Weight kg
4KTC 90 S-8/6	0.38	830	1.35	2.6	1.5	34	4KTC 180 L-8/6	7.5	870	18	5.2	1.7	240
	0.50	1150	1.5	3.1	1.5			10.5	1180	24	5.9	1.5	
4KTC 90 L-8/6	0.50	830	1.68	2.6	1.3	36	4KTC 200 L-8/6	11	870	23	5.2	2.0	260
	0.65	1150	2.07	3.3	1.5			14	1180	27	6.5	1.8	
4KTC 100 LA-8/6	0.65	860	2.05	2.8	1.4	45	4KTC 225 S-8/6	14	870	29	5.0	1.5	320
	0.85	1160	2.15	3.9	1.5			17	1170	36	5.9	1.2	
4KTC 100 LB-8/6	0.8	850	2.4	2.9	1.4	49	4KTC 225 M-8/6	18	870	42	5.1	1.5	400
	1.0	1160	2.5	3.9	1.5			24	1170	54	6.2	1.2	
4KTC 112 M-8/6	1.0	860	2.8	4.0	1.6	64	4KTC 250 M-8/6	24	880	51	5.5	1.6	490
	1.3	1160	3.0	4.8	1.9			33	1180	65	6.2	1.4	
4KTC 132 S-8/6	1.6	870	5.05	4.6	2.1	89	4KTC 280 S-8/6	30	880	63	5.5	1.5	610
	2.2	1170	5.5	5.9	2.0			38	1180	80	6.2	1.3	
4KTC 132 M-8/6	2.4	870	6.8	3.7	1.8	99	4KTC 280 M-8/6	36	880	74	5.7	1.5	685
	3.3	1170	8.1	5.0	1.9			45	1180	90	6.4	1.3	
4KTC 160 M-8/6	3.8	870	8.8	5.2	2.0	155	4KTC 315 S-8/6	44	880	90	5.7	1.5	820
	5.5	1170	12.0	6.1	1.8			55	1180	102	6.6	1.2	
4KTC 160 L-8/6	5.5	870	12.0	5.2	2.0	197	4KTC 315 M-8/6	53	880	103	5.7	1.5	930
	7.5	1170	16.0	6.1	1.9			68	1180	125	6.6	1.2	



*Technical data and tables with ratings
for pole changing motors - ventilator drive*

Three-phase motor with short-circuit rotor

Pole number 4/2

Y/YY 380 - 415 V 50 Hz

Protection class IP 55
Temperature class T1 - T4
Thermal class F

Explosion protection													
Certificate	Type 4KTC or 4KTCD						Type 4KTC			Type 4KTC			
	71	80	90	100	112	132	160	180	200	225	250	280	315
PTB 99 ATEX 1138	●						●						
PTB 99 ATEX 1005		●	●	●	●	●							
PTB 00 ATEX 1080													
PTB 05 ATEX 1054								●					
PTB 05 ATEX 1099									●				
PTB 05 ATEX 1100										●			
PTB 03 ATEX 1127											●		
PTB 03 ATEX 1141												●	
PTB 03 ATEX 1126													●

Selection chart

Type	Power kW	Speed min ⁻¹	In (A) 400 Volt	Starting current (IA/IN)	Max. torque (MM/MN)	Weight kg	Type	Power kW	Speed min ⁻¹	In (A) 400 Volt	Starting current (IA/IN)	Max. torque (MM/MN)	Weight kg
4KTC 71 A-4/2	0,09 0,37	1320 2740	0.35 1.1	2.8 3.6	1.7 1.5	16	4KTC 160 L-4/2	3.8 15.5	1450 2920	7.4 31	7.9 8.1	2.2 2.2	189
4KTC 71 B-4/2	0,14 0,5	1330 2800	0.5 1.3	2.7 4.3	1.9 2.9	16	4KTC 180 M-4/2	5 18	1460 2930	12 34	7 7.2	2 2	220
4KTC 80 A-4/2	0,17 0,75	1400 2810	0.58 1.85	3.6 4.7	2.2 2.1	25	4KTC 180 L-4/2	6 24	1450 2925	14.5 44	7.2 7.3	2.1 2.1	240
4KTC 80 B-4/2	0,2 0,95	1385 2780	0.64 2.5	3.8 4.2	1.8 1.9	28	4KTC 200 L-4/2	8 30	1460 2940	18.5 57	7.2 7.3	1.9 2	260
4KTC 90 S-4/2	0,37 1,4	1430 2810	0.8 3.1	5.6 5.3	2.4 2	34	4KTC 225 S-4/2	9,2 37	1460 2960	21 68	7 7.3	2 2.1	320
4KTC 90 L-4/2	0,5 2	1445 2880	1.2 4.6	5.8 6.4	2.4 2.2	36	4KTC 225 M-4/2	11,5 44	1450 2970	23 81	7 7.2	2 2	400
4KTC 100 LA-4/2	0,6 2,6	1430 2880	1.6 5.7	5.3 6.5	2.2 1.7	45	4KTC 250 M-4/2	15 55	1470 2950	29 97	5 6.3	2 2.2	490
4KTC 100 LB-4/2	0,85 3,2	1410 2870	2 6.8	4.7 5.7	1.8 2	49	4KTC 280 S-4/2	20 75	1475 2965	36 125	5.5 7	1.8 2	610
4KTC 112 M-4/2	1,1 4,4	1450 2880	2.5 8.5	6.2 6.6	2.1 2	64	4KTC 280 M-4/2	24 90	1480 2970	44 149	5.6 7.4	1.9 2.2	685
4KTC 132 S-4/2	1,7 6,0	1455 2890	3.8 12.4	5.9 6.3	2 2.3	89	4KTC 315 S-4/2	27 110	1485 2980	48 179	5 6.2	1.3 1.2	820
4KTC 132 M-4/2	2 8	1450 2920	4.2 18	7 7.3	1.9 2.1	99	4KTC 315 MA-4/2	33 132	1485 2980	59 215	5 6.2	1.3 1.2	930
4KTC 160 M-4/2	2.9 11	1450 2920	6.2 24.5	7 7.1	1.9 2.1	169	4KTC 315 MB-4/2	37 145	1485 2980	70 237	5.2 6.8	1.2 1.2	1240



Three-phase motor with short-circuit rotor

Pole number 8/4

Y/YY 380 - 415 V 50 Hz

Protection class IP 55
 Temperature class T1 - T4
 Thermal class F

Explosion protection													
Certificate	Type 4KTC or 4KTCD						Type 4KTC			Type 4KTC			
	71	80	90	100	112	132	160	180	200	225	250	280	315
PTB 99 ATEX 1138	●						●						
PTB 99 ATEX 1005		●	●	●	●	●							
PTB 00 ATEX 1080													
PTB 05 ATEX 1054								●					
PTB 05 ATEX 1099									●				
PTB 05 ATEX 1100										●			
PTB 03 ATEX 1127											●		
PTB 03 ATEX 1141												●	
PTB 03 ATEX 1126													●

Selection chart

Type	Power kW	Speed min ⁻¹	In 400 V A	Starting current (IA/IN)	Max. torque (MM/MN)	Weight kg	Type	Power kW	Speed min ⁻¹	In 400 V A	Starting current (IA/IN)	Max. torque (MM/MN)	Weight kg
4KTC 71 A-8/4	0.05 0.2	700 1420	0.39 0.82	1.7 3.5	1.4 1.8	16	4KTC 160MB-8/4	3 10	725 1470	10 22	3.3 6.6	1.9 2.7	165
4KTC 71 B-8/4	0.07 0.3	680 1390	0.44 0.95	1.8 3.6	1.6 1.8	17	4KTC 180 M-8/4	4 16	735 1465	13 30	4.5 6.1	1.9 2.4	220
4KTC 80 A-8/4	0.1 0.45	690 1425	0.53 1.45	2.4 4.7	1.7 2.4	25	4KTC 180 L-8/4	4.5 19	730 1470	14.5 38.5	4 6.6	2.1 2.4	240
4KTC 80 B-8/4	0.13 0.6	690 1435	0.69 1.9	2.35 4.7	1.9 2.7	28	4KTC 200 L-8/4	6.2 25	720 1470	14.5 46	4.4 6.8	2.2 2.3	260
4KTC 90 S-8/4	0.18 0.8	700 1415	0.76 1.9	2.8 5	1.8 2	34	4KTC 225 S-8/4	7.5 30	725 1470	19 60	4.6 6.7	2.3 2.4	320
4KTC 90 L-8/4	0.3 1.2	700 1435	1.24 2.9	3 5.6	2 2.3	36	4KTC 225 M-8/4	9 37	730 1475	22 67	4.8 7	2.4 2.8	400
4KTC 100 LA-8/4	0.33 1.6	710 1435	1.45 3.7	3.1 5.1	1.3 1.5	45	4KTC 250 M-8/4	12 48	730 1475	24.5 82	5 5.8	2.2 2.4	490
4KTC 100 LB-8/4	0.55 2.2	695 1430	2 4.9	2.8 5	1.6 1.8	49	4KTC 280 S-8/4	16 65	740 1485	42 127	4.3 7.5	1.8 2.1	610
4KTC 112 M-8/4	0.75 3	705 1440	2.44 6.1	3.2 6.5	1.7 2	64	4KTC 280 M-8/4	20 80	740 1485	48 140	4.3 7.5	1.8 2.2	685
4KTC 132 S-8/4	1.1 4.4	710 1450	3.5 9	2.8 5.3	1.5 2	89	4KTC 315 S-8/4	24 98	735 1485	45 165	4.6 7	1.4 1.8	820
4KTC 132 M-8/4	1.3 5.1	720 1460	4 10.2	3.5 6.9	3.1 2.6	99	4KTC 315 M-8/4	30 120	740 1485	52 196	4.6 7	1.4 1.8	930
4KTC 160 MA-8/4	1.8 7.5	725 1465	4.6 14.8	5.3 7.6	1.8 2	155							



Three-phase motor with short-circuit rotor

Pole number 6/4

Y/Y 380 - 415 V 50 Hz

Protection class IP 55
 Temperature class T1 - T4
 Thermal class F

Explosion protection	 												
Certificate	Type 4KTC or 4KTCD						Type 4KTC			Type 4KTC			
	71	80	90	100	112	132	160	180	200	225	250	280	315
PTB 99 ATEX 1138	●						●						
PTB 99 ATEX 1005		●	●	●	●	●							
PTB 00 ATEX 1080													
PTB 05 ATEX 1054								●					
PTB 05 ATEX 1099									●				
PTB 05 ATEX 1100										●			
PTB 03 ATEX 1127											●		
PTB 03 ATEX 1141												●	
PTB 03 ATEX 1126													●

Selection chart

Type	Power kW	Speed min ⁻¹	In 400 V A	Starting current (IA/IN)	Max. torque (MM/MN)	Weight kg	Type	Power kW	Speed min ⁻¹	In 400 V A	Starting current (IA/IN)	Max. torque (MM/MN)	Weight kg
4KTC 71 B-6/4	0.1 0.3	960 1450	0.83 1	2.8 4	1.9 2.1	16	4KTC 180 M-6/4	5.2 15	960 1450	12 31.5	6 6.9	1.6 1.8	220
4KTC 80 A-6/4	0.13 0.44	930 1430	0.49 1.4	3.8 4.2	1.2 1.6	25	4KTC 180 L-6/4	6.2 18.5	965 1450	14.5 36	6.2 7	1.6 1.8	240
4KTC 80 B-6/4	0.18 0.59	950 1430	0.67 1.6	3.6 4	1.9 1.7	28	4KTC 200 L-6/4	8.8 25	970 1465	18.5 48.5	6.2 6.4	2.1 2.1	260
4KTC 90 S-6/4	0.29 0.8	950 1430	1.05 2.2	3.4 4.3	1.5 1.5	34	4KTC 225 S-6/4	11 30	985 1480	23.7 57	6.25 6.2	2.1 2.1	320
4KTC 90 L-6/4	0.37 1.1	960 1430	1.38 2.65	3.7 5.2	2.4 2	36	4KTC 225 M-6/4	14 38	980 1470	30 71	6 6.1	2 2.1	400
4KTC 100LA-6/4	0.5 1.5	960 1440	1.65 3.6	3.6 4.8	1.6 1.6	45	4KTC 250 M-6/4	18 52	985 1480	34 87	6.5 7.5	2.3 2.4	490
4KTC 100LB-6/4	0.75 2.2	970 1460	3.1 6.8	4 5.4	1.6 1.8	49	4KTC 280 S-6/4	25 70	985 1480	45 126	6.5 7	1.9 1.7	610
4KTC 112 M-6/4	0.9 3	940 1445	2.43 6.4	4.1 4.8	1.7 1.6	64	4KTC 280 M-6/4	30 80	985 1485	55 141	6.5 7	2 1.8	685
4KTC 132 S-6/4	1.2 4	980 1460	4.6 9.5	5.1 6.5	1.7 2	89	4KTC 315 S-6/4	40 105	985 1480	63 170	6 6	2.4 2	820
4KTC 132 M-6/4	1.7 5.5	960 1460	6.1 13	5.5 6.8	2 1.9	99	4KTC 315 M-6/4	50 120	985 1480	70 200	6 7	2.3 2.2	930
4KTC 160 M-6/4	2.5 7.5	980 1465	7.4 16.5	6 7.4	2.2 2.1	155							
4KTC 160 L-6/4	3.3 11	985 1475	8.8 23.1	6 7.3	2.7 2.6	197							



Three-phase motor with short-circuit rotor

Pole number 4/2

Y/YY 440 - 480 V 60 Hz

Protection class IP 55
 Temperature class T1 - T4
 Thermal class F

Explosion protection													
Certificate	Type 4KTC or 4KTCD						Type 4KTC			Type 4KTC			
	71	80	90	100	112	132	160	180	200	225	250	280	315
PTB 99 ATEX 1138	●						●						
PTB 99 ATEX 1005		●	●	●	●	●							
PTB 00 ATEX 1080													
PTB 05 ATEX 1054								●					
PTB 05 ATEX 1099									●				
PTB 05 ATEX 1100										●			
PTB 03 ATEX 1127											●		
PTB 03 ATEX 1141												●	
PTB 03 ATEX 1126													●

Selection chart

Type	Power kW	Speed min ⁻¹	In 440 V A	Starting current (IA/IN)	Max. torque (MM/MN)	Weight kg	Type	Power kW	Speed min ⁻¹	In 440 V A	Starting current (IA/IN)	Max. torque (MM/MN)	Weight kg
4KTC 71 A-4/2	0.1 0.4	1585 3290	0.35 1.1	2.7 3.4	1.6 1.4	16	4KTC 160 L-4/2	4.2 17	1740 3500	7.4 31	7.5 7.7	2.0 2.0	189
4KTC 71 B-4/2	0.15 0.55	1600 3360	0.5 1.3	2.6 4.1	1.8 2.7	16	4KTC 180 M-4/2	5.5 20	1750 3520	12 34	6.6 6.8	1.9 1.9	220
4KTC 80 A-4/2	0.18 0.9	1690 3355	0.51 1.94	4.0 3.8	2.7 2.2	25	4KTC 180 L-4/2	6.6 26	1740 3510	14.5 44	6.8 6.9	2.0 2.0	240
4KTC 80 B-4/2	0.27 1.1	1660 3340	0.64 2.5	3.6 4.0	1.7 1.8	28	4KTC 200 L-4/2	8.8 33	1750 3530	18.5 57	6.8 6.9	1.8 1.9	260
4KTC 90 S-4/2	0.4 1.5	1720 3370	0.8 3.1	5.3 5.0	2.2 1.9	34	4KTC 225 S-4/2	10 41	1750 3550	21 68	6.6 6.9	1.9 2.0	320
4KTC 90 L-4/2	0.55 2.2	1730 3460	1.2 4.6	5.5 6.1	2.2 2.0	36	4KTC 225 M-4/2	12.5 48	1740 3560	23 81	6.6 6.8	1.9 1.9	400
4KTC 100 LA-4/2	0.65 2.9	1720 3460	1.6 5.7	5.0 6.2	2.0 1.6	45	4KTC 250 M-4/2	16.5 60	1760 3540	29 97	4.8 6.0	1.9 2.0	490
4KTC 100 LB-4/2	0.95 3.5	1690 3440	2.0 6.8	4.5 5.4	1.7 1.9	49	4KTC 280 S-4/2	22 82	1770 3560	36 125	5.2 6.6	1.7 1.9	610
4KTC 112 M-4/2	1.2 4.8	1740 3460	2.5 8.5	5.9 6.3	2.0 1.9	64	4KTC 280 M-4/2	26 100	1780 3560	44 149	5.3 7.0	1.8 2.0	685
4KTC 132 S-4/2	1.9 6.6	1750 3470	3.8 12.4	5.6 6.0	1.9 2.1	89	4KTC 315 S-4/2	30 120	1780 3580	48 179	4.7 5.9	1.2 1.1	820
4KTC 132 M-4/2	2.2 8.8	1740 3500	4.2 18	6.6 7.0	1.8 2.0	99	4KTC 315 MA-4/2	36 145	1780 3580	59 215	4.7 5.9	1.2 1.1	930
4KTC 160 M-4/2	3.2 12.6	1740 3500	6.2 24.5	6.6 6.7	1.8 2.0	169	4KTC 315 MB-4/2	40 160	1780 3580	70 237	5.0 6.5	1.1 1.1	1240



Three-phase motor with short-circuit rotor

Pole number 8/4

Y/YY 440 - 480 V 60 Hz

Protection class IP 55
 Temperature class T1 - T4
 Thermal class F

Explosion protection													
Certificate	Type 4KTC or 4KTCD						Type 4KTC			Type 4KTC			
	71	80	90	100	112	132	160	180	200	225	250	280	315
PTB 99 ATEX 1138	●						●						
PTB 99 ATEX 1005		●	●	●	●	●							
PTB 00 ATEX 1080													
PTB 05 ATEX 1054								●					
PTB 05 ATEX 1099									●				
PTB 05 ATEX 1100										●			
PTB 03 ATEX 1127											●		
PTB 03 ATEX 1141												●	
PTB 03 ATEX 1126													●

Selection chart													
Type	Power	Speed	In	Starting	Max.	Weight	Type	Power	Speed	In	Starting	Max.	Weight
	kW	min ⁻¹	440 V A	current (IA/IN)	torque (MM/MN)	kg		kW	min ⁻¹	440 V A	current (IA/IN)	torque (MM/MN)	kg
4KTC 71 A-8/4	0.06 0.22	840 1700	0.39 0.82	1.6 3.3	1.3 1.7	16	4KTC 160 MB-8/4	3.3 11	870 1760	10 22	3.1 6.3	1.8 2.5	165
4KTC 71 B-8/4	0.08 0.33	820 1670	0.44 0.95	1.7 3.4	1.5 1.7	17	4KTC 180 M-8/4	4.4 17.6	875 1765	11.2 31	3.8 6.5	1.7 2.3	220
4KTC 80 A-8/4	0.11 0.5	830 1710	0.53 1.45	2.3 4.5	1.6 2.2	25	4KTC 180 L-8/4	4.5 18	880 1775	12.8 33	4.0 7.6	2.0 2.2	240
4KTC 80 B-8/4	0.14 0.65	830 1720	0.69 1.9	2.2 4.5	1.8 2.5	28	4KTC 200 L-8/4	6 30	885 1775	14.3 51	6.4 8.7	2.0 2.1	260
4KTC 90 S-8/4	0.2 0.9	840 1700	0.76 1.9	4.8 2.7	1.7 1.9	34	4KTC 225 S-8/4	9 35	870 1760	19 60	4.4 6.4	2.1 2.2	320
4KTC 90 L-8/4	0.33 1.32	834 1715	1.16 2.9	3.4 5.15	2.1 2.7	36	4KTC 225 M-8/4	10 41	880 1770	22 67	4.6 6.7	2.2 2.6	400
4KTC 100 LA-8/4	0.45 2.0	840 1705	1.4 3.95	2.9 4.7	1.2 1.4	45	4KTC 250 M-8/4	11 50	880 1770	24.5 82	4.8 5.5	2.0 2.2	490
4KTC 100 LB-8/4	0.6 2.4	845 1730	2.15 5.1	3.0 5.5	2.1 2.7	49	4KTC 280 S-8/4	19 75	890 1780	42 127	4.1 7.1	1.7 2.0	610
4KTC 112 M-8/4	0.8 3.3	850 1730	2.44 6.1	3.0 6.2	1.6 1.9	64	4KTC 280 M-8/4	22 88	890 1780	48 140	4.1 7.1	1.7 2.0	685
4KTC 132 S-8/4	1.2 4.8	850 1740	3.5 9.0	2.7 5.0	1.4 1.9	89	4KTC 315 S-8/4	24 105	880 1780	45 165	4.4 6.7	1.3 1.7	820
4KTC 132 M-8/4	1.15 5.75	865 1745	3.45 10.4	3.7 6.5	2.9 2.4	99	4KTC 315 M-8/4	29 126	890 1780	52 196	4.4 6.7	1.3 1.7	930
4KTC 160 MA-8/4	1.6 8.0	875 1755	4.0 14.2	5.6 7.3	1.7 1.9	155							



Three-phase motor with short-circuit rotor

Pole number 6/4

Y/Y 440 - 480 V 60 Hz

Protection class IP 55
 Temperature class T1 - T4
 Thermal class F

Explosion protection													
Certificate	Type 4KTC or 4KTCD						Type 4KTC			Type 4KTC			
	71	80	90	100	112	132	160	180	200	225	250	280	315
PTB 99 ATEX 1138	●						●						
PTB 99 ATEX 1005		●	●	●	●	●							
PTB 00 ATEX 1080													
PTB 05 ATEX 1054								●					
PTB 05 ATEX 1099									●				
PTB 05 ATEX 1100										●			
PTB 03 ATEX 1127												●	
PTB 03 ATEX 1141													●
PTB 03 ATEX 1126													●

Selection chart

Type	Power kW	Speed min ⁻¹	In 440 V A	Starting current (IA/IN)	Max. torque (MM/MN)	Weight kg	Type	Power kW	Speed min ⁻¹	In 440 V A	Starting current (IA/IN)	Max. torque (MM/MN)	Weight kg
4KTC 71 B-6/4	0.11	1150	0.83	2.7	1.8	16	4KTC 180 M-6/4	5.7	1150	12	5.7	1.5	220
	0.33	1740	1	1.0	2.0			16.5	1740	31.5	6.6	1.7	
4KTC 80 A-6/4	0.14	1120	0.49	3.6	1.1	25	4KTC 180 L-6/4	6.8	1160	14.5	5.9	1.5	240
	0.48	1720	1.4	4.0	1.5			20	1740	36	6.6	1.7	
4KTC 80 B-6/4	0.2	1140	0.67	3.4	1.8	28	4KTC 200 L-6/4	10	1160	18.5	5.9	2.0	260
	0.65	1720	1.6	3.8	1.6			28	1760	48.5	6.1	2.0	
4KTC 90 S-6/4	0.32	1140	1.05	3.2	1.4	34	4KTC 225 S-6/4	12	1180	23.7	5.9	2.0	320
	0.88	1720	2.2	4.1	1.4			33	1780	57	6.2	2.0	
4KTC 90 L-6/4	0.4	1150	1.38	3.5	2.2	36	4KTC 225 M-6/4	15	1180	30	5.7	1.9	400
	1.2	1720	2.65	4.9	1.9			42	1760	71	5.8	2.0	
4KTC 100 LA-6/4	0.55	1150	1.65	3.4	1.5	45	4KTC 250 M-6/4	19	1180	34	6.2	2.1	490
	1.65	1730	3.6	4.6	1.5			53	1780	87	7.1	2.2	
4KTC 100 LB-6/4	0.82	1160	3.1	3.8	1.5	49	4KTC 280 S-6/4	27	1180	45	6.2	1.8	610
	2.4	1750	6.8	5.1	1.7			77	1780	126	6.7	1.6	
4KTC 112 M-6/4	1.0	1130	2.43	3.9	1.6	64	4KTC 280 M-6/4	33	1180	55	6.2	1.9	685
	3.3	1730	6.4	4.6	1.5			90	1780	141	6.7	1.7	
4KTC 132 S-6/4	1.3	1180	4.6	4.8	1.6	89	4KTC 315 S-6/4	35	1180	63	5.7	2.2	820
	4.4	1750	9.5	6.2	1.9			105	1780	170	5.7	1.9	
4KTC 132 M-6/4	1.9	1150	6.1	5.2	1.9	99	4KTC 315 M-6/4	41	1180	70	5.7	2.1	930
	6.0	1750	13	6.5	1.8			126	1780	200	6.7	2.0	
4KTC 160 M-6/4	2.7	1180	7.4	5.7	2.0	155							
	8.2	1760	16.5	7.0	2.0								
4KTC 160 L-6/4	3.6	1180	8.8	5.7	2.5	197							
	12.0	1770	23.1	6.9	2.4								



Three-phase electric motors driven by frequency inverters

General description

The asynchronous motor with its short-circuit rotor and robust construction offers an excellent price-performance ratio. AC motors are designed for constant speed operation. It is not possible to change speed when they are running on fixed frequency supplies. There are drives which require the additional flexibility of smooth speed variations and this is best achieved with the use of an inverter.

Frequency inverters provide an excellent speed and the speed can be varied continuously over the entire frequency range. To avoid overheating, three PTC elements are built into the head of the winding. As the speed rises (higher frequency), the motor becomes louder. Voltage type frequency inverters cause a noise increase of about 7 to 15 dB, current type ones of about 3 dB.

We strongly recommend that you indicate frequency range and working characteristics of the motor ($T = f(n)$ or $P = f(n)$) when placing your order.

Power and torque characteristics of motors driven by frequency inverters

We distinguish two ranges:

0 - 50 Hz range

Here the motor develops its normal torque on the shaft at 5 to 10 Hz of the output frequency (10 - 20 % of the nominal speed). The motor maintains the nominal torque at the shaft until the frequency reaches 50 Hz (100 % of the nominal speed). Voltage keeps rising while the magnetic flux is kept constant. The power increase in this range is linear to the revolutions ($P = k \times M \times n$).

50 - 87 Hz range

Here the torque falls parallel to the speed. The voltage of the motor is maintained on a constant level while the magnetic flux is weaker. The current level is maintained and independent of the speed.

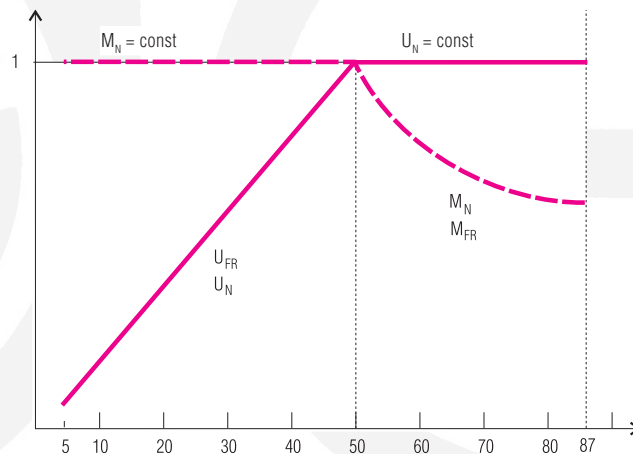

U_N = net voltage

U_{FR} = voltage of frequency inverter

M_N = motor torque on net

M_{FR} = motor torque on frequency inverter



Three-phase motor with short-circuit rotor

Pole number 2

Explosion protection: II 2G EEx d IIC T4 or II 2G EEx de IIC T4

Selection chart

Operating	net	frequency inverter	frequency inverter	frequency inverter	frequency inverter	frequency inverter	frequency inverter	frequency inverter
Cooling	own	own	own	own	own	own	forced cooling	own
Torque		T - n ²	constant	constant	constant	constant	constant	constant
Frequency	50 Hz	5 to 50 Hz	20 to 50 Hz	10 to 50 Hz	5 to 50 Hz	50 to 87 Hz	5 to 87 Hz	50 to 87 Hz*
Ratio		1 : 10	1 : 2.5	1 : 5	1 : 10	1 : 1.74	1 : 17.4	1 : 1.74
RPM		300 - 3000 min ⁻¹	1200 - 3000 min ⁻¹	600 - 3000 min ⁻¹	300 - 3000 min ⁻¹	3000 - 5220 min ⁻¹	300 - 5220 min ⁻¹	3000 - 5220 min ⁻¹
V/f		U/f = const	U/f = const	U/f = const	U/f = const	U = const	U = const	U/f = const**

Type	Power kW	Power 50 Hz	Torque Nm	Power 50 Hz	Torque Nm	Power 50 Hz	Torque Nm	Power 50 Hz	Torque Nm	Power 87 Hz	Torque Nm	Power 87 Hz	Torque Nm	Power 87 Hz	Torque Nm
4KTC 71 A-2	0.37	0.35	1.12	0.32	1.07	0.3	0.97	0.22	0.74	0.35	0.65	0.35	0.65	0.6	1.12
	0.55	0.53	1.7	0.47	1.62	0.45	1.47	0.33	1.1	0.53	0.98	0.53	0.98	0.9	1.7
4KTC 80 A-2	0.75	0.72	2.3	0.65	2.2	0.6	2.0	0.5	1.7	0.7	1.33	0.7	1.33	1.2	2.3
	1.1	1	3.4	0.95	3.25	0.9	3.0	0.75	2.5	1.1	2.0	1.1	2.0	1.8	3.4
4KTC 90 S-2	1.5	1.4	4.5	1.3	4.3	1.2	4.0	1.0	3.3	1.4	2.6	1.4	2.6	2.5	4.5
	2.2	2.1	6.7	1.9	6.4	1.7	5.7	1.4	4.7	2.1	3.8	2.1	3.8	3.7	6.7
4KTC 100 L-2	3.0	2.8	9	2.6	8.6	2.2	7.2	1.8	5.9	2.8	5.2	2.8	5.2	4.9	9
4KTC 112 M-2	4.0	3.8	12	3.4	11.4	3.2	10.4	2.5	8.2	3.8	6.9	3.8	6.9	6.5	12
4KTC 132 SA-2	5.5	5.1	16.3	4.7	15.6	4.5	14.1	3.7	12.0	5.1	9.4	5.1	9.4	8.9	16.3
	7.5	6.9	22	6.5	21.1	6.0	19.1	5.0	16.0	7.0	12.7	7.0	12.7	12.0	22
4KTC 160 MA-2	11.0	10	32.2	9.5	30.8	8.8	27.9	7.5	24.0	10.2	18.6	10.2	18.6	17.6	32.2
	15.0	13.5	43.8	12.9	41.9	12.0	38	10.0	32.0	13.8	25.3	13.8	25.3	24.0	43.8
	18.5	16.6	54	15.9	51.6	15.0	46.8	12.0	41.0	17.0	31.2	17.0	31.2	29.5	54
4KTC 180 M-2	22.0	20	64.4	18.9	61.5	18.0	55.8	15.0	49.0	20.3	37.2	20.3	37.2	35.0	64.4
4KTC 200 LA-2	30.0	27	87	25.8	83.4	24.0	75.7	21	68	27.6	50.4	27.6	50.4	47.0	87
	37.0	33	107	31.8	102.4	28.0	90.0	26	84	34.0	62.0	34.0	62.0	58.0	107
4KTC 225 M-2	45	40	130	37.0	119.0	34.0	110.0	32.0	101	-	-	-	-	-	-
4KTC 250 M-2	55	50	159	45	145	43	138	39	124	-	-	-	-	-	-
4KTC 280 S-2	75	67	217	60	193	58	186	53	169	-	-	-	-	-	-
	90	81	260	73	234	70	225	63	202	-	-	-	-	-	-
4KTC 315 S-2	110	100	318	90	288	88	282	78	247	-	-	-	-	-	-
	132	119	382	110	353	105	331.0	93	297	-	-	-	-	-	-
	160	144	458	135	433	125	398	112	358	-	-	-	-	-	-
	200	180	575	165	528	156	498	140	447	-	-	-	-	-	-

* range 60 to 87 Hz, motors with steel fan ** U = 230/400 V



Three-phase motor with short-circuit rotor

Pole number 4

Explosion protection: II 2G EEx d IIC T4 or II 2G EEx de IIC T4

Selection chart								
Operating	net	frequency inverter	frequency inverter	frequency inverter	frequency inverter	frequency inverter	frequency inverter	frequency inverter
Cooling	own	own	own	own	own	own	forced cooling	own
Torque		T - n ²	constant	constant	constant	constant	constant	constant
Frequency	50 Hz	5 to 50 Hz	20 to 50 Hz	10 to 50 Hz	5 to 50 Hz	50 to 87 Hz	5 to 87 Hz	50 to 87 Hz*
Ratio		1 : 10	1 : 2.5	1 : 5	1 : 10	1 : 1.74	1 : 17.4	1 : 1.74
RPM		150 - 1500 min ⁻¹	600 - 1500 min ⁻¹	300 - 1500 min ⁻¹	150 - 1500 min ⁻¹	1500 - 2610 min ⁻¹	150 - 2610 min ⁻¹	1500 - 2610 min ⁻¹
V/f		U/f = const	U/f = const	U/f = const	U/f = const	U = const	U = const	U/f = const**

Type	Power kW	Power 50 Hz	Torque Nm	Power 50 Hz	Torque Nm	Power 50 Hz	Torque Nm	Power 50 Hz	Torque Nm	Power 87 Hz	Torque Nm	Power 87 Hz	Torque Nm	Power 87 Hz	Torque Nm
4KTC 71 A-4 B-4	0.25	0.25	1.57	0.23	1.5	0.21	1.35	0.19	1.2	0.25	0.9	0.25	0.9	0.43	1.57
	0.37	0.36	2.3	0.34	2.2	0.31	2.0	0.28	1.8	0.35	1.3	0.35	1.3	0.63	2.3
4KTC 80 A-4 B-4	0.55	0.53	3.38	0.5	3.2	0.45	2.9	0.4	2.6	0.55	2.0	0.55	2.0	0.92	3.38
	0.75	0.72	4.6	0.69	4.4	0.62	4.0	0.56	3.6	0.71	2.6	0.71	2.6	1.2	4.6
4KTC 90 S-4 L-4	1.1	1.05	6.7	1.0	6.4	0.9	5.8	0.8	5.2	1.05	3.9	1.05	3.9	1.8	6.7
	1.5	1.4	9.1	1.4	8.7	1.2	7.9	1.1	7.1	1.4	5.2	1.4	5.2	2.5	9.1
4KTC 100 LA-4 LB-4	2.2	2.1	13.4	2.0	12.8	1.8	11.6	1.6	10.4	2.1	7.7	2.1	7.7	3.6	13.4
	3.0	2.8	18.2	2.7	17.4	2.5	15.7	2.2	14.1	2.9	10.5	2.9	10.5	5.0	18.2
4KTC 112 M-4	4.0	3.8	24.0	3.6	22.9	3.2	20.7	2.9	18.6	3.8	13.8	3.8	13.8	6.5	24.0
4KTC 132 S-4 M-4	5.5	5.2	33.0	5.0	31.5	4.5	28.5	4.0	25.6	5.2	19.0	5.2	19.0	9.0	33.0
	7.5	7.0	44.5	6.7	42.6	6.0	38.6	5.4	34.6	7.0	25.7	7.0	25.7	12.0	44.5
4KTC 160 M-4 L-4	11.0	10.0	64.5	9.7	61.7	8.8	56.0	7.8	50.0	10.2	37.3	10.2	37.3	17.0	64.5
	15.0	14.0	88.0	13.2	84	12.0	76.3	10.7	68.0	13.9	50.8	13.9	50.8	24.0	88.0
4KTC 180 M-4 L-4	18.5	17.0	108.5	16.3	104	14.8	94.0	13.2	84.0	17.1	62.7	17.1	62.7	30.0	108.5
	22.0	20.0	129.0	19.3	123	17.6	112.0	15.7	100.0	20.4	74.5	20.4	74.5	35.0	129.0
4KTC 200 L-4	30.0	28.0	176.0	26.4	168	23.9	152.0	21.0	136.0	27.7	101.5	27.7	101.5	48.0	176.0
4KTC 225 S-4 M-4	37.0	34.0	216.0	32.3	206	29.4	187.0	26.0	168.0	34.2	125.0	34.2	125.0	-	-
	45.0	41	262	39,3	250	35.6	227.0	32.0	204	41	151	41	151	-	-
4KTC 250 M-4	55	50	320	48	305	43.5	277	39	248	50	185	50	185	-	-
4KTC 280 S-4 M-4	75	68	434	65	415	59	376	53	337	68	250	68	250	-	-
	90	82	520	78	497	70	450	64	405	82	300	82	300	-	-
4KTC 315 S-4 MA-4 MB-4 L-4	110	100	635	95	607	86	550	77	494	100	367	100	367	-	-
	132	120	766	115	732	104	664	94	596	121	442	121	442	-	-
	160	145	924	138	883	126	801	113	719	146	534	146	534	-	-
	200	180	1154	173	1102	157	1000	140	897	182	666	182	666	-	-

* range 60 to 87 Hz, motors with steel fan ** U = 230/400 V



Three-phase motor with short-circuit rotor

Pole number 6

Explosion protection: II 2G EEx d IIC T4 or II 2G EEx de IIC T4

Selection chart

Operating	net	frequency inverter	frequency inverter	frequency inverter	frequency inverter	frequency inverter	frequency inverter	frequency inverter
Cooling	own	own	own	own	own	own	forced cooling	own
Torque		T - n ²	constant	constant	constant	constant	constant	constant
Frequency	50 Hz	5 to 50 Hz	20 to 50 Hz	10 to 50 Hz	5 to 50 Hz	50 to 87 Hz*	5 to 87 Hz*	50 to 87 Hz*
Ratio		1 : 10	1 : 2.5	1 : 5	1 : 10	1 : 1.74	1 : 17.4	1 : 1.74
RPM		100 - 1000 min ⁻¹	400 - 1000 min ⁻¹	200 - 1000 min ⁻¹	100 - 1000 min ⁻¹	1000 - 1740 min ⁻¹	100 - 1740 min ⁻¹	1000 - 1740 min ⁻¹
V/f		U/f = const	U/f = const	U/f = const	U/f = const	U = const	U = const	U/f = const**

Type	Power kW	Power 50 Hz	Torque Nm	Power 50 Hz	Torque Nm	Power 50 Hz	Torque Nm	Power 50 Hz	Torque Nm	Power 87 Hz	Torque Nm	Power 87 Hz	Torque Nm	Power 87 Hz	Torque Nm
4KTC 71 B-6	0.25	0.24	2.3	0.23	2.2	0.21	2.0	0.19	1.8	0.24	1.3	0.24	1.3	0.42	2.3
4KTC 80 A-6	0.37	0.36	3.4	0.35	3.3	0.31	3.0	0.28	2.7	0.36	2.0	0.36	2.0	0.62	3.4
B-6	0.55	0.53	5.1	0.51	4.9	0.46	4.4	0.42	4.0	0.55	3.0	0.55	3.0	0.93	5.1
4KTC 90 S-6	0.75	0.73	7.0	0.7	6.7	0.64	6.1	0.57	5.5	0.73	4.0	0.73	4.0	1.27	7.0
L-6	1.1	1.08	10.3	1.04	9.9	0.94	9	0.84	8.0	1.1	6.0	1.1	6.0	1.9	10.3
4KTC 100 L-6	1.5	1.45	13.9	1.38	13.2	1.25	12	1.1	10.8	1.45	8.0	1.45	8.0	2.5	13.9
4KTC 112 M-6	2.2	2.05	19.7	2	18.8	1.8	17	1.6	15.3	2.1	11.4	2.1	11.4	3.6	19.7
4KTC 132 S-6	3	2.8	26.5	2.6	25.3	2.4	23	2.1	20.6	2.8	15.3	2.8	15.3	4.8	26.5
MA-6	4	3.8	36	3.6	34.3	3.2	31	2.9	28	3.8	20.7	3.8	20.7	6.5	36
MB-6	5.5	5.2	50	4.9	47	4.5	43	4.0	38	5.3	29	5.3	29	9.1	50
4KTC 160 M-6	7.5	7.0	67	6.7	64	6	58	5.4	52	6.9	38	6.9	38	12.2	67
L-6	11	10.3	98	9.8	94	8.9	85	8.0	76	10.4	57	10.4	57	17.8	98
4KTC 180 L-6	15	14.0	133	13	127	12	115	10.9	104	14.0	77	14.0	77	24.2	133
4KTC 200 LA-6	18.5	17.3	165	16	157	15.0	143	13.4	128	17.3	95	17.3	95	30.0	165
LB-6	22	20.6	197	19	188	17.8	170	16	153	20.8	114	20.8	114	36	197
4KTC 225 M-6	30	27.5	264	26	252	24	228	21.5	205	27.7	152	27.7	152	-	-
4KTC 250 M-6	37	34	323	32	308	29	280	26	251	34	187	34	187	-	-
4KTC 280 S-6	45	41	393	39	376	35	340	32	306	41	227	41	227	-	-
M-6	55	50	481	48	459	43	416	39	374	50	278	50	278	-	-
4KTC 315 S-6	75	69	659	65	629	58	571	54	512	69	381	69	381	-	-
MA-6	90	82	787	78	752	71	681	64	612	83	454	83	454	-	-
MB-6	110	100	960	96	917	87	831	78	746	101	554	101	554	-	-
L-6	132	120	1150	115	1100	104	997	94	895	121	665	121	665	-	-

* range 60 to 87 Hz, motors with steel fan ** U = 230/400 V



Three-phase motor with short-circuit rotor

Pole number 8

Explosion protection: II 2G EEx d IIC T4 or II 2G EEx de IIC T4

Selection chart								
Operating	net	frequency inverter	frequency inverter	frequency inverter	frequency inverter	frequency inverter	frequency inverter	frequency inverter
Cooling	own	own	own	own	own	own	forced cooling	own
Torque		T - n ²	constant	constant	constant	constant	constant	constant
Frequency	50 Hz	5 to 50 Hz	20 to 50 Hz	10 to 50 Hz	5 to 50 Hz	50 to 87 Hz*	5 to 87 Hz*	50 to 87 Hz*
Ratio		1 : 10	1 : 2.5	1 : 5	1 : 10	-	-	1 : 1.74
RPM		75 - 750 min ⁻¹	300 - 750 min ⁻¹	150 - 750 min ⁻¹	75 - 750 min ⁻¹	750 - 1305 min ⁻¹	75 - 1305 min ⁻¹	750 - 1305 min ⁻¹
V/f		U/f = const	U/f = const	U/f = const	U/f = const	U = const	U = const	U/f = const**

Type	Power kW	Power 50 Hz	Torque Nm	Power 50 Hz	Torque Nm	Power 50 Hz	Torque Nm	Power 50 Hz	Torque Nm	Power 87 Hz	Torque Nm	Power 87 Hz	Torque Nm	Power 87 Hz	Torque Nm
4KTC 71 B-8	0.12	0.12	1.57	0,11	1,5	0.11	1.4	0.09	1.2	0.12	0.9	0.12	0.9	0,21	1.57
4KTC 80 A-8	0.18	0.18	2.3	0.17	2.2	0.16	2.0	0.14	1.8	0.18	1.3	0.18	1.3	0,31	2.3
B-8	0.25	0.25	3.2	0.23	3.0	0.21	2.7	0.2	2.5	0.25	1.8	0.25	1.8	0.44	3.2
4KTC 90 S-8	0.37	0.37	4.7	0.35	4.5	0.31	4.0	0.28	3.6	0.37	2.7	0.37	2.7	0.64	4.7
L-8	0.55	0.54	6.9	0.52	6.6	0.47	6.0	0.42	5.4	0.55	4.0	0.55	4.0	0.94	6.9
4KTC 100LA-8	0.75	0.74	9.4	0.7	8.9	0.64	8.1	0.57	7.3	0.75	5.4	0.75	5.4	1.3	9.4
LB-8	1.1	1.05	13.5	1.0	12.9	0.92	11.7	0.82	10.5	1.1	7.8	1.1	7.8	1.8	13.5
4KTC 112 M-8	1.5	1.4	18.2	1.35	17.4	1.24	15.8	1.1	14.1	1.4	10.5	1.4	10.5	2.5	18.2
4KTC 132 S-8	2.2	2.1	26.6	2	25.5	1.8	23.1	1.6	20.7	2.1	15.4	2.1	15.4	3.6	26.6
M-8	3	2.8	36.4	27	35.0	2.5	31.5	2.2	28.3	2.9	21.0	2.9	21.0	5.0	36.4
4KTC 160MA-8	4	3.8	48	3.6	46	3.2	41.4	2.9	37.2	3.8	27.6	3.8	27.6	6.5	48
MB-8	5.5	5.2	66	4.9	63	4.5	57.4	4.0	51.5	5.2	38.3	5.2	38.3	9	66
L-8	7.5	7.0	89	6.7	85	6	77	5.4	69.2	7.0	51.4	7.0	51.4	12	89
4KTC 180 L-8	11	10.4	132	9.9	126	9	115	8.0	103	10.4	76	10.4	76	18	132
4KTC 200 L-8	15	13.8	176	13.2	168	12	153	10.8	137	14	102	14	102	24	176
4KTC 225 S-8	18.5	17.6	224	16.8	214	15	194	14	174	17.6	129	17.6	129	-	-
M-8	22	21	265	20	253	18	229	16	206	21	153	21	153	-	-
4KTC 250 M-8	30	28	358	27	342	24	310	22	279	28	207	28	207	-	-
4KTC 280 S-8	37	34	436	33	417	30	378	27	339	34	252	34	252	-	-
M-8	45	41	527	40	504	36	457	32	410	42	305	42	305	-	-
4KTC 315 S-8	55	50	644	48	616	44	558	39	501	51	372	51	372	-	-
MA-8	75	68	872	65	833	59	756	53	678	69	504	69	504	-	-
MB-8	90	81	1030	77	985	70	893	63	801	81	595	81	595	-	-
L-8	110	99	1260	95	1204	86	1092	77	980	99	728	99	728	-	-

* range 60 to 87 Hz, motors with steel fan ** U = 230/400 V



Mounting dimensions

The mounting dimensions allow the following tolerances:

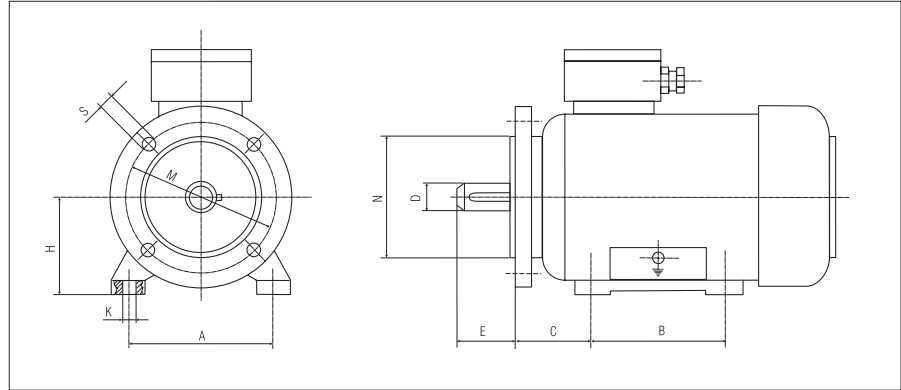

Dimension		Tolerance
A, B	≤ 250 mm	± 0.75 mm
	> 250 mm ... 500 mm	± 1.00 mm
	> 500 mm ... 750 mm	± 1.50 mm
H	> 50 mm ... 250 mm	- 0.50 mm
	> 250 mm ... 630 mm	- 1.00 mm
C	≤ 85 mm	± 1.00 mm
	> 85 mm ... 130 mm	± 2.00 mm
	> 130 mm ... 240 mm	± 3.00 mm
	> 240 mm ... 500 mm	± 4.00 mm
M	≤ 200 mm	± 0.25 mm
	> 200 mm ... 500 mm	± 0.50 mm
	> 500 mm	± 1.00 mm
K and S	+ 3 % diameter	
E	≤ 30 mm	- 0.20 mm
	> 30 mm ... 110 mm	- 0.30 mm
D	≤ Ø 50 mm	k 6
	≥ Ø 50 mm	m 6
N	≤ 230 mm	j 6
	≥ 250 mm	h 6



Dimensions 4KTC

Form IM B3

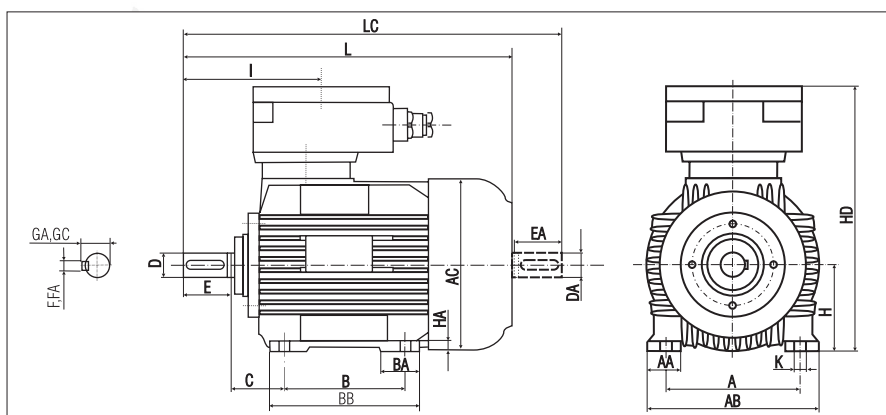

Dimensions																							
Frame size	A	AA	AB	AC	B	BA	BB	C	D	DA	E	EA	F	FA	GC	GA	H	HA	HD	I	K	L	LC
4KTC 71 A, B	112	30	140	139	90	30	114	45	14	30	5	16	71	10	218	114	9	271	307				
4KTC 80 A, B	125	32	160	157	100	35	130	50	19	40	6	21.5	80	10	249	131	10	317	362				
4KTC 90 S, L	140	35	180	177	125	60	155	56	24	50	8	27	90	10	271	140	10	360	415				
4KTC 100 L	160	45	205	195	140	45	175	63	28	60	8	31	100	17	288	158	12	416	481				
4KTC 112 M	190	50	235	219	140	50	180	70	28	60	8	31	112	15	311	159	12	438	504				
4KTC 132 S M	216	55	266	258	178	75	218 210	89	38	80	10	41	132	18	350	181	12	534	619				
4KTC 160 M L	254	60	312	310	254	105	300	108	42	110	12	45	160	21	436	255	14	667	785				
4KTC 180 M L	279	70	350	345	241 279	118	333	121	48	110	14	51	180	22	496	297	14	704	742				
4KTC 200 L	318	80	398	385	305	95	365	133	55	110	16	59	200	22	546	308	18	790	830				
4KTC 225 S M-2 M	356	80	436	435	286 311 311	110	371	149	60 55 60	140 110 140	18 16 18	64 59 64	225	23	589	341 311 341	18	882 852 882	922 892 922				
4KTC 250 M-2 M	406	100	506	491	349	90	429	168	60 65	140	18	64 69	250	23	687	380	24	997	1152				
4KTC 280 S-2 S M-2 M	457	110	557	537	386 368 419 419	100	454 454 505 505	190	65 75 65 75	140	18 20 18 20	69 79.5 69 79.5	280	23	744	382	24	1036 1036 1096 1096	1191 1191 1224 1224				
4KTC 315 S-2 S MA-2 MA MB-2 MB L-2 L	508	110	628	617	406 406 457 457 457 457 457	115	526 526 577 577 577 577 577	216	65 80 65 65 65 65 80	140 170 140 140 140 140 170	18 22 18 18 18 18 22	69 85 69 69 69 85 85	315	25	859	454 484 454 484 454 484 454	28	1050 1080 1220 1250 1220 1250 1300 1330	1210 1270 1380 1440 1380 1440 1460 1520				



Dimensions 4KTC

Form IM B5 (V1)

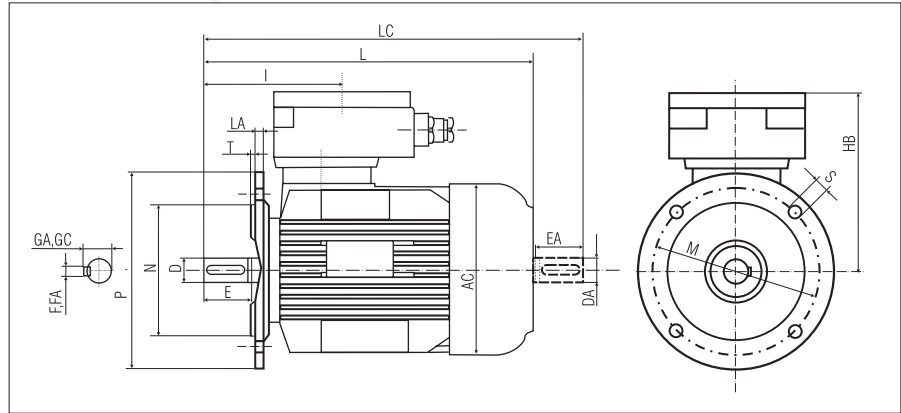

Dimensions

Frame size	Flange	AC	D DA	E EA	F FA	GC GA	HB	I	L	LA	LC	M	N	P	S	No. of fixing holes	T
4KTC 71 A, B	F 130-I	139	14	30	5	16	147	114	271	10	307	130	110	160	9	4	3.5
4KTC 80 A, B	F 165-I	157	19	40	6	21.50	169	131	317	10	362	165	130	200	12	4	3.5
4KTC 90 S, L	F 165-I	177	24	50	8	27	181	140	360	10	415	165	130	200	12	4	3.5
4KTC 100 L	F 215-I	195	28	60	8	31	188	158	416	11	481	215	180	250	14	4	4
4KTC 112 M	F 215-I	219	28	60	8	31	199	159	438	11	504	215	180	250	14	4	4
4KTC 132 S, M	F 265-I	258	38	80	10	41	218	181	534	16	619	265	230	300	14	4	4
4KTC 160 M, L	F 300-I	310	42	110	12	45	276	255	667	19	785	300	250	350	18	4	5
4KTC 180 M L	F 300-I F 300-I	345	48	110	14	51	316	297	704	15	742	300	250	350	18	4	5
4KTC 200 L	F 350-I	385	55	110	16	59	346	308	790	18	830	350	300	400	18	4	5
4KTC 225 S M-2 M	F 400-I F 400-I F 400-I	435	60 55 60	140 110 140	18 16 18	64 59 64	364	341 311 341	882 852 882	18	922 892 922	400	350	450	18	8	5
4KTC 250 M-2 M	F 500-I F 500-I	491	60 65	140	18	64 69	437	380	997	18	1152	500	450	550	19	8	5
4KTC 280 S-2 S M-2 M	F 500-I F 500-I F 500-I F 500-I	537	65 75 65 75	140	20 18 20	69 79.50 69 79.50	464	382	1036 1036 1096 1096	18	1191 1191 1224 1224	500	450	550	19	8	5
4KTC 315 S-2 S MA-2 MA MB-2 MB L-2 L	F 600-I F 600-I F 600-I F 600-I F 600-I F 600-I F 600-I F 600-I	617	65 80 65 80 65 80 65 80	140 170 140 170 140 170 140 170	18 22 18 22 18 22 18 22	69 85 69 85 69 85 69 85	544	454 484 454 484 454 484 454 484	1050 1080 1220 1250 1220 1250 1300 1330	18	1210 1270 1380 1440 1380 1440 1460 1520	600	550	660	24	8	6



Dimensions 4KTC

Form IM B3/B5

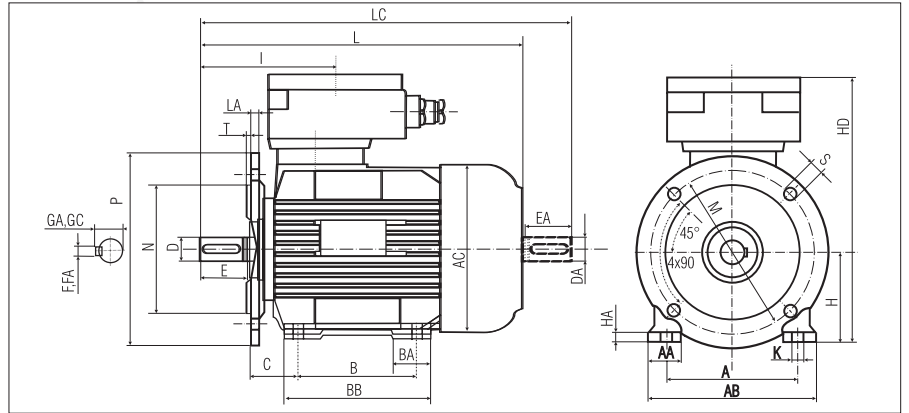

Dimensions																														
Frame size	Flange	A	AA	AB	AC	B	BA	BB	C	D	DA	E	EA	F	FA	GC	GA	H	HA	HD	I	K	L	LA	LC	M	N	P	S	No. of fixing holes
4KTC 71 A, B	F 130-I	112	30	140	139	90	30	114	45	14	30	5	16	71	10	218	114	9	271	10	307	130	110	160	9	4				
4KTC 80 A, B	F 165-I	125	32	160	157	100	35	130	50	19	40	6	21.5	80	10	249	131	10	317	10	362	165	130	200	12	4				
4KTC 90 S, L	F 165-I	140	35	180	177	125	60	155	56	24	50	8	27	90	10	271	140	10	360	10	415	165	130	200	12	4				
4KTC 100 L	F 215-I	160	45	205	195	140	45	175	63	28	60	8	31	100	17	288	158	12	416	11	481	215	180	250	14	4				
4KTC 112 M	F 215-I	190	50	235	219	140	45	180	70	28	60	8	31	112	15	311	159	12	438	11	504	215	180	250	14	4				
4KTC 132 S, M	F 265-I	216	55	266	258	140 178 210	75	218	89	38	80	10	41	132	18	350	181	12	534	16	619	265	230	300	14	4				
4KTC 160 M, L	F 300-I	254	60	312	310	254	90	300	108	42	110	12	45	160	21	436	255	14	667	19	785	300	250	350	18	4				
4KTC 180 M-2 L	F 300-I	279	70	350	345	241 279	118	333	121	48	110	14	51	180	22	496	297	14	704	15	742	300	250	350	18	4				
4KTC 200 L	F 350-I	318	80	398	385	305	95	365	133	55	110	16	59	200	22	546	308	18	790	18	830	350	300	400	18	4				
4KTC 225 S M-2 M	F 400-I F 400-I F 400-I	356	80	436	435	311 286 311	110	371	149	60 55 60	140 110 140	18 16 18	64 59 64	225	23	589	311 311 341	18	852 852 882	18	922 892 922	400	350	450	18	8				
4KTC 250 M-2 M	F 500-I F 500-I	406	100	506	491	349	90	429	158	60 65	140	18	64 69	250	23	687	380	24	997	18	1152	500	450	550	19	8				
4KTC 280 S-2 S M-2 M	F 500-I F 500-I F 500-I F 500-I	457	110	557	537	368 368 419 419	100	454 454 505 505	190	65 75 65 75	140	18 20 18 20	69 79.5 69 79.5	280	23	744	382	24	1036 1036 1096 1096	18	1191 1191 1224 1224	500	450	550	19	8				
4KTC 315 S-2 S MA-2 MA MB-2 MB L-2 L	F 600-I F 600-I F 600-I F 600-I F 600-I F 600-I F 600-I	508	110	628	617	406 406 457 457 457 457	115	526 526 577 577 577 577	216	65 80 65 80 65 80	140 170 140 170 140 170	18 22 18 22 18 22	69 85 69 85 69 85	315	25	859	454 484 454 484 454 484	28	1050 1080 1220 1250 1220 1250	18	1210 1270 1380 1440 1380 1440	600	550	660	24	8				



Dimensions 4KTC

Form IM B3/B14

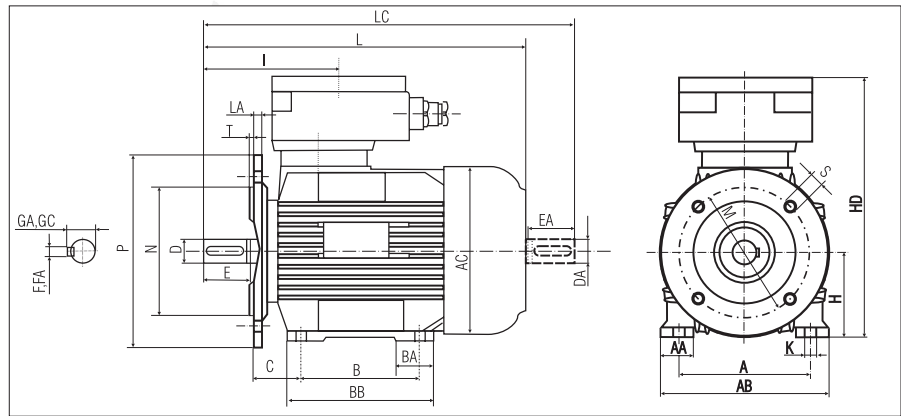

Dimensions

Frame size	Flange	A	AA	AB	AC	B	BA	BB	C	D	E	F	GC	H	HA	HD	I	K	L	LC	M	N	P	S	No. of fixing holes	T
4KTC 71 A, B	F 85-II	112	30	140	139	90	30	114	45	14	30	5	16	71	10	218	114	9	271	307	85	70	105	M6	4	2.5
	F 115-II																				115	95	140	M8	4	3
4KTC 80 A, B	F 100-II	125	32	160	157	100	35	130	50	19	40	6	21.5	80	10	249	131	10	317	362	100	80	120	M6	4	3
	F 130-II																				130	110	160	M8	4	3.5
4KTC 90 S, L	F 115-II	140	35	180	177	100	60	155	56	24	50	8	27	90	10	271	140	10	360	415	115	95	140	M8	4	3
	F 130-II					125															130	110	160	M8	4	3.5
4KTC 100 L	F 130-II	160	45	205	195	140	45	175	63	28	60	8	31	100	17	288	158	12	416	481	130	110	160	M8	4	3.5
	F 165-II																				165	130	200	M10	4	3.5
4KTC 112 M	F 130-II	190	50	235	219	140	50	180	70	28	60	8	31	112	15	311	159	12	438	504	130	110	160	M8	4	3.5
	F 165-II																				165	130	200	M10	4	3.5



Dimensions 4KTC

Form IM B14

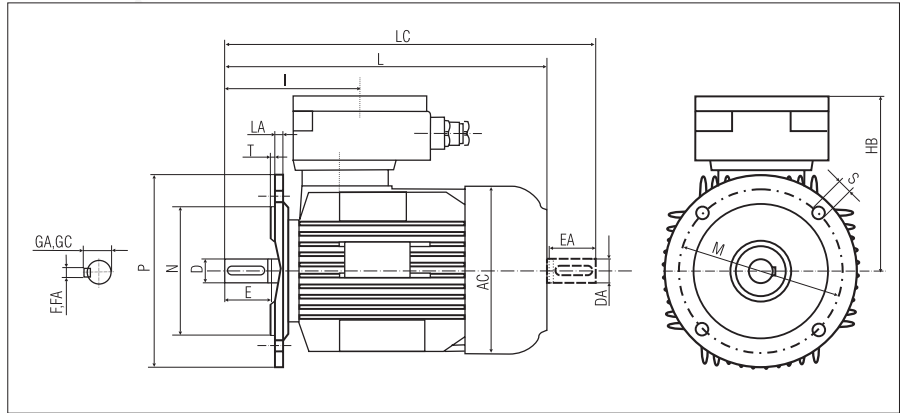

Dimensions																	
Frame size	Flange	AC	D DA	E EA	F FA	GC GA	HB	I	L	LC	M	N	P	S	No. of fixing holes	T	
4KTC 71 A, B	F 85-II	139	14	30	5	16	147	114	271	307	85	70	105	M6	4	2.5	
	F 115-II										115	95	140	M8	4	3	
4KTC 80 A, B	F 100-II	157	19	40	6	21.5	169	131	317	362	100	80	120	M6	4	3	
	F 130-II										130	110	160	M8	4	3.5	
4KTC 90 L, S	F 115-II	177	24	50	8	27	181	140	360	415	115	95	140	M8	4	3	
	F 130-II										130	110	160	M8	4	3.5	
4KTC 100 L	F 130-II	195	28	60	8	31	188	158	416	481	130	110	160	M8	4	3.5	
	F 165-II										165	130	200	M10	4	3.5	
4KTC 112 M	F 130-II	219	28	60	8	31	199	159	438	504	130	110	160	M8	4	3.5	
	F 165-II										165	130	200	M10	4	3.5	



Special execution

EEx brake

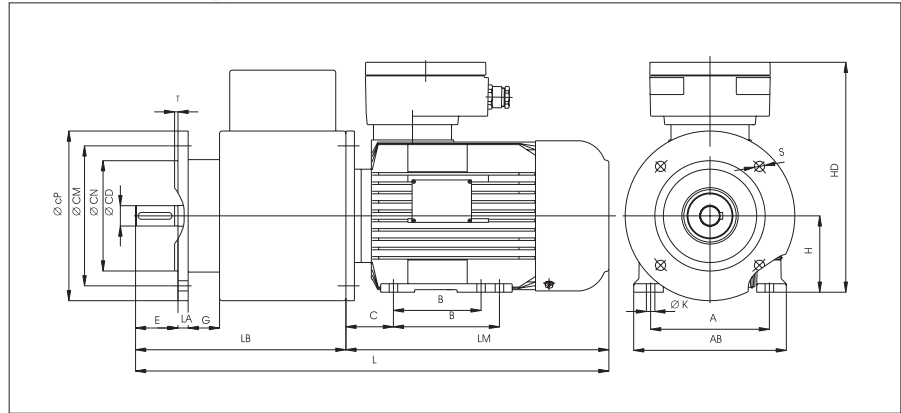

Dimensions

motor	brake	A	AB	B	C	∅D	E	G	H	∅K	LA	LB	LM	L	∅M	∅N	∅P	∅S	
4 KTC 71	A,B	71	112	140	90	45	14	30	28	71	9	10	175	242	417	130	110	160	9
4 KTC 80	A,B	80	125	160	100	50	19	40	37	80	10	12	238	277	515	165	130	299	11
4 KTC 90	S L	90 90	140	180	100 125	56	24	50	37	90	10	12	248	310	558	165	130	200	11
4 KTC 100	L	100/112	160	205	140	63	28	60	39	100	12	12	276	356	632	215	180	250	14
4 KTC 112	M	100/112	160	235	140	70	28	60	45	112	12	12	276	378	654	215	180	250	14
4 KTC 132	S M	132	216	266	140 178	89	38	80	45	132	12	18	323	454	777	265	230	300	14
4 KTC 160	M L	160	254	312	210 254	108	42	110	45	160	14	18	353	558	911	300	250	350	16
4 KTC 180	M L	180	279	350	241 279	121	48	110	46	180	14	21	412	597	1009	300	250	350	18
4 KTC 200	L	200	398	398	305	133	55	110	46	200	18	21	412	686	1098	350	300	400	18



Special execution

Encoder

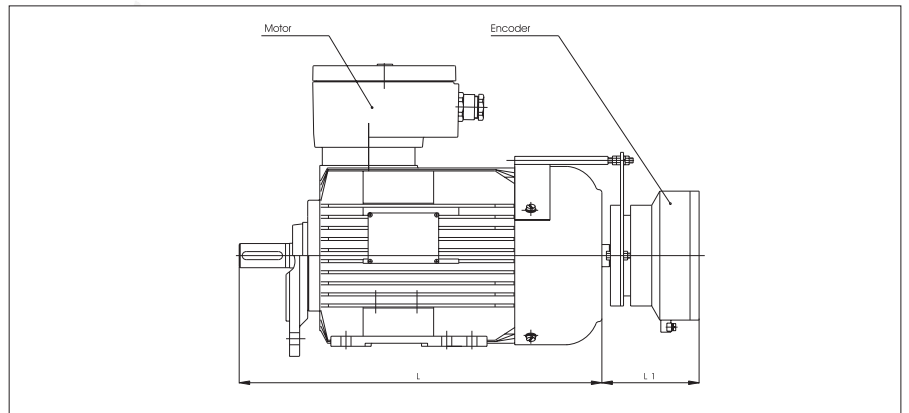

Dimensions

Motor	L	Encoder (L1) Liende & Liende	Encoder (L1) Kuebler
4KTC 71 A, B	271	105	125
4KTC 80 A, B	317	105	125
4KTC 90 L	360	105	125
4KTC 100 L	416	105	125
4KTC 112 M	438	105	125
4KTC 132 S, M	534	105	125
4KTC 160 M, L	667	105	125
4KTC 180 M, L	707	105	125
4KTC 200 L	796	105	125
4KTC 225 M-2	852	105	125
4KTC 225 S, M-4, 6, 8	882	105	125
4KTC 250 M	997	105	125
4KTC 280 S	1036	105	125
4KTC 280 M	1096	105	125
4KTC 315 S-2	1050	105	125
4KTC 315 S-4, 6, 8	1080	105	125
4KTC 315 M-2	1220	105	125
4KTC 315 M-4, 6, 8	1250	105	125
4KTC 315 L-2	1300	105	125
4KTC 315 L-4, 6, 8	1330	105	125



Special execution

Forced cooling

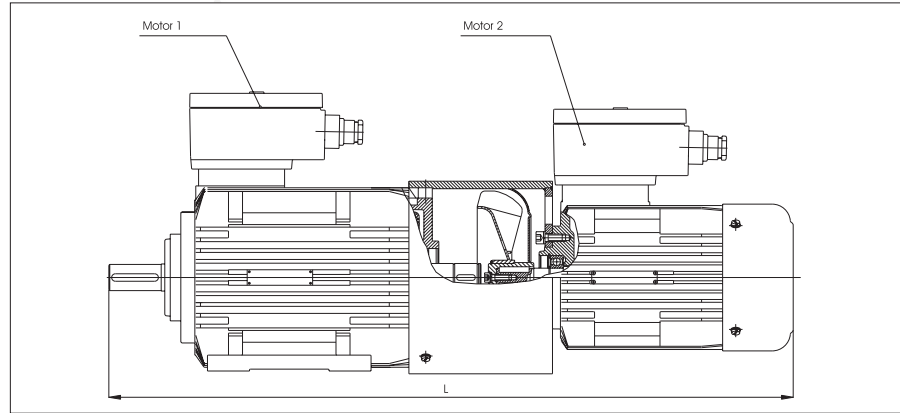

Dimensions

Motor 1			Motor 2			L (mm)
4KTC	80	A, B	4KTC	71	A2	614
4KTC	90	S, L	4KTC	71	A2	637
4KTC	100	L	4KTC	71	A2	695
4KTC	112	M	4KTC	71	A2	726
4KTC	132	S, M	4KTC	71	A2	822
4KTC	160	M, L	4KTC	71	A2	954
4KTC	180	M, L	4KTC	80	A4	1022
4KTC	200	L	4KTC	80	A4	1120
4KTC	225	M-2	4KTC	80	A4	1184
4KTC	225	S, M-4, 6, 8	4KTC	80	A4	1214
4KTC	250	M	4KTC	90	L4	1330
4KTC	280	S	4KTC	90	L4	1369
4KTC	280	M	4KTC	90	L4	1429
4KTC	315	S-2	4KTC	90	L4	1380
4KTC	315	S-4, 6, 8	4KTC	90	L4	1410
4KTC	315	M-2	4KTC	90	L4	1550
4KTC	315	M-4, 6, 8	4KTC	90	L4	1580
4KTC	315	L-2	4KTC	90	L4	1630
4KTC	315	L-4, 6, 8	4KTC	90	L4	1660



Special execution

Direct cable entry

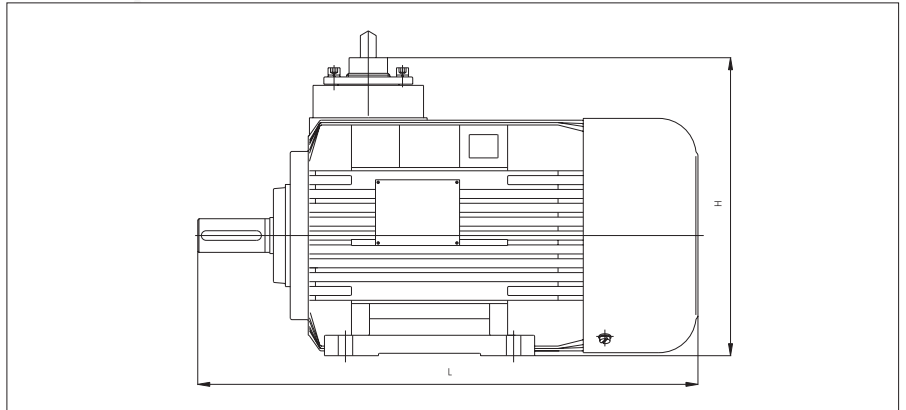

Dimensions

Motor	L	H
4KTC 71 A, B	272	191
4KTC 80 A, B	317	207
4KTC 90 S, L	360	226
4KTC 100 L	416	243
4KTC 112 M	438	267
4KTC 132 S, M	534	307
4KTC 160 M, L	668	371
4KTC 180 M, L	707	430
4KTC 200 L	796	478
4KTC 225 S, M-2	852	523
4KTC 225 S, M-4, 6, 8	882	523
4KTC 250 M	997	613

* Cable details on request



Special applications

Frame Size	71	80	90	100	112	132	160	180	200	225	250	280	315
Special voltage up to 759 V	●	●	●	●	●	●	●	●	●	●	●	●	●
Special frequency	●	●	●	●	●	●	●	●	●	●	●	●	●
Frequency inverter drive	●	●	●	●	●	●	●	op	op	op	op	op	op
Special power	op	op	op	op	op	op	op	op	op	op	op	op	op
Special shaft end	op	op	op	op	op	op	op	op	op	op	op	op	op
Free shaft end on NDS-end of motor	●	●	●	●	●	●	●	●	●	●	●	●	●
Special flange	op	op	op	op	op	op	op	op	op	op	op	op	op
Flange made in R acc. to DIN 42955	●	●	●	●	●	●	●	●	●	●	●	●	●
Additional greasing							●	●	●	●	●	●	●
Fixed bearing on AS								●	●	●	●	●	●
2RS bearings	●	●	●	●	●	●	●	●	●	●	●	●	●
Labyrinth seal							●	●	●	●	●	●	●
Oil seal								●	●	●	●	●	●
Protection IP 56	●	●	●	●	●	●	●	●	●	●	●	●	●
Protection IP 65	op	op	op	op	op	op	op	op	op	op	op	op	op
Protection IP 66	op	op	op	op	op	op	op	op	op	op	op	op	op
Protection cover	●	●	●	●	●	●	●	●	●	●	●	●	●
Vibrations within R or S limits	●	●	●	●	●	●	●	●	●	●	●	●	●
Plastic ventilator								●	●	●	●	●	●
SPM placing							op	op	op	op	op	op	op
Special data plate	●	●	●	●	●	●	●	●	●	●	●	●	●
Terminal box with EEx d cable glands	op	op	op	op	op	op	op	op	op	op	op	op	op
Tropical version	●	●	●	●	●	●	●	●	●	●	●	●	●
Thermal protection of winding	●	●	●	●	●	●	●	●	●	●	●	●	●
Thermal protection of bearings							●	●	●	●	●	●	●
Heating of winding against condensation	●	●	●	●	●	●	●	●	●	●	●	●	●
Heating of winding at temp. lower - 20 °C	●	●	●	●	●	●	●	●	●	●	●	●	●
Insulation class H	●	●	●	●	●	●	●	●	●	●	●	●	●
VIK execution	●	●	●	●	●	●	●	●	●	●			
Marine execution (LRS)	●	●	●	●	●	●	●	●	●	●	●	●	●
Special colour	●	●	●	●	●	●	●	●	●	●	●	●	●

● on request
op = option

Ordering data

- Rating in kW
- Voltage and frequency
- Start connection (on-line or star-delta)
- R. p. m.
- Type of motor arrangement
- Type of explosion protection (gas group and T-classification)
- Mechanical requirements
- Special requirements (i. e. H-class thermal insulation, two-shaft, radial bearing seals).